



Northern Lights Solutions

In Partnership with Orde Street Public School



2020 Green Energy Challenge Proposal

June 1, 2020

CECA/NECA

University of Toronto Student Chapter



Table of Contents

1	Project Summary	4
1.1	Executive Summary	4
1.2	NLS Mission Statement	4
1.3	Our Client.....	5
1.3.1	Our Client Facility	6
1.4	Our Team	6
2	Technical Analysis 1: Energy Efficiency Analysis	12
2.1	Energy Audit Results	12
2.1.1	General Electrical System.....	12
2.1.2	Existing Lighting Fixtures and Controls.....	13
2.1.3	HVAC Motor Controls.....	14
2.2	Energy Benchmark.....	14
2.3	DOE Building Assessment.....	15
2.4	Recommendations.....	16
2.4.1	Thermaliner Curtains/Roll-Down Blackout Shades.....	16
2.4.2	Double Panel and Vinyl Framed Windows.....	16
2.4.3	Electric Boiler	17
2.4.4	Electric Water Heaters	17
2.4.5	AC Unit.....	18
2.5	Contributions to Net-Zero and Return on Investment.....	18
3	Technical Analysis 2: Lighting Retrofit.....	19
3.1	Existing Lighting System.....	19
3.2	Proposed Lighting Retrofits	20
3.2.1	Recommendation 1: LED Replacement.....	20
3.2.2	Recommendation 2: Light Shelf	20
3.2.3	Recommendation 3: Dimmer Switch.....	21
3.3	Ceiling Plan.....	21
3.4	Photometric Analysis Drawing	22
3.5	Return on Investment Report.....	23
3.6	Contributions to Net Zero	24



4	Technical Analysis 3: Solar Energy System	25
4.1	Existing Conditions.....	25
4.1.1	Selected Location.....	25
4.2	Connection Details.....	25
4.3	Shading Studies.....	26
4.3.1	Shading Analysis.....	26
4.3.2	PV Tilt Recommendation.....	27
4.4	Component Selection	28
4.4.1	Panels	28
4.4.2	Ballasted Flat Roof Racking System.....	28
4.4.3	Combiner Box	28
4.4.4	Inverter	29
4.5	Schematic Drawing of PV System.....	29
4.5.1	Three-Line Diagram.....	30
4.6	Solar Energy Summary	30
4.6.1	Cost Summary.....	30
4.6.2	System Challenges	30
4.6.3	Incentives and Rebates.....	31
4.6.4	Net-Zero Recommendation.....	31
4.6.5	CO2 Pollution Analysis	31
5	Schematic Estimate, Schedule, and Finance Plan	31
5.1	Cost Estimate	31
5.2	Scheduling.....	31
5.3	Safety	32
5.4	Cash Flow Plan	35
5.4.1	Incentives and Rebates.....	35
5.4.2	Loans.....	35
5.4.3	Financial Analysis.....	35
6	Outreach	36
6.1	Energy Awareness Campaign and Volunteering at OSPS	36
6.1.1	Description of Lessons.....	36



6.1.2	Blog Posts	37
6.1.3	Web Game – “Power Dilemma”	38
6.1.4	Letter from OSPS.....	38
6.2	Other Efforts to Increase Awareness of the Green Energy Challenge.....	39
6.2.1	Gemini House Tour.....	39
6.2.2	Green Energy Challenge Workshops	39
6.3	Local NECA/CECA Chapter Interactions	39
6.4	Letter from Campus and Local Media Engagement	40
7	References	41
8	Appendix A – Product Data Sheets for Technical Analysis 1.....	48
9	Appendix B – Product Data Sheets for Technical Analysis 2.....	51
10	Appendix C – Product Data Sheets for Technical Analysis 3.....	58
11	Appendix D – Volunteering Log.....	66



1 Project Summary

1.1 Executive Summary

This year, Northern Lights Solutions (NLS) partnered with Orde Street Public School (OSPS). Located in downtown Toronto, this school serves children from kindergarten through Grade 8. The building was constructed in 1914 and has been renovated several times since. It has a floor area of 77,000 ft² across 3 floors and a basement. Its 25 classrooms serve 500 students during the school year, a Japanese school on weekends, and a daycare year-round. NLS conducted an energy audit of the building and learned that it uses 1400 MWh of energy/year: 200 MWh of electricity and 1200 MWh of natural gas. The natural gas is almost exclusively used for space and water heating. The electricity is used in a 30/30/40 split between plug loads, lighting, and cooling respectively.

NLS developed several recommendations for the facility to reduce its energy usage: insulating blackout curtains to reduce solar gains when undesirable, new vinyl framed windows, new electric boiler and heater, and new AC units. Together, these systems will save OSPS 65% of its current energy use. A further 5% energy is saved in the lighting retrofits, which include new LED light bulbs, occupancy sensors, dimmer switches, and light shelves to spread natural light into the interior of the classrooms. Finally, 8% of the current energy use of OSPS can be offset by installing 317 Solar PV panels on the roof. Together, these retrofits will reduce the energy use of OSPS to 80% of what it currently consumes. To reduce it further, OSPS will have to consider several disruptive retrofits, such as increased insulation and air tightness retrofits or on-site geothermal generation. Should OSPS want to achieve net zero energy, not contained on site, they could buy time on an Ontario wind farm, which could be counted against the energy used by the school. The total project costs are approximately \$445,950 CAD, with \$2960 CAD of maintenance costs annually. The payback period of the project is just over 4 years.

NLS also undertook significant community engagement efforts this year. A case competition in the fall was published in Daily Commercial News, and the team's efforts will be featured in the upcoming June edition of the school newsletter. The team also ran several workshops, and a tour of a low-energy home on campus. After the COVID-19 lockdown began, the team created videos and lesson plans for the students at OSPS, to help them engage with thinking about sustainable buildings. NLS published several blog posts on the CECA U of T student chapter website. Finally, a web game was prototyped for students to further explore green energy.

1.2 NLS Mission Statement

NLS empowers students to transform energy in the built environment through education and application, while assisting them with their professional development through industry engagement.



1.3 Our Client

Orde Street Public School (OSPS), part of the Toronto District School Board, is situated in the central portion of the City of Toronto. This facility (Figure 1) was built in 1914 to support the growing community of immigrants establishing themselves in Toronto [1]. Today, it continues to serve this diverse community by providing a range of educational services, from junior kindergarten to grade 8, to over 450 students from more than 30 countries worldwide [1].

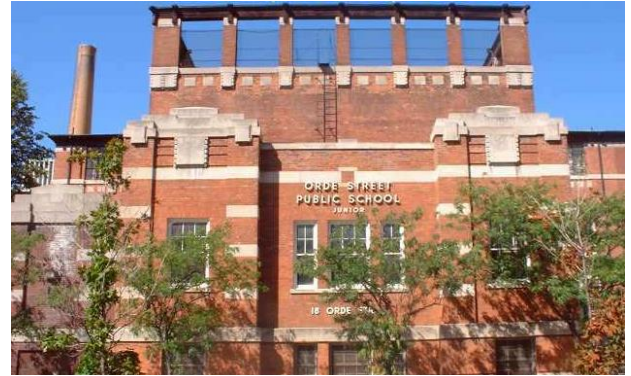

Figure 1 Orde Street Public School [1]

OSPS offers a diverse curriculum that challenges students to grow and develop through rich academic and extracurricular programs [2]. The school encourages its children to broaden their minds from a young age through exposure to cultures from around the world. With that in mind, OSPS focuses on strengthening the literacy skills of its students and children in the community through an International Languages Integrated Day Program and weekend classes teaching Chinese, Mandarin, Arabic, and Japanese [1][2]. To allow these children to explore other interests, OSPS hosts a variety of other educational programs after school, such as chess club, coding programs, and knitting club [2]. In addition to educational services, OSPS offers an on-site daycare centre that supervises children before and after school to support working parents [1].

OSPS remains committed to providing the best quality learning experience for all students with the help of the local community. Through the support of a Digital Lead Learner from the Toronto District School Board, the school has transformed its library into a Learning Commons that seamlessly combines technology with traditional teaching methods to allow students to explore new ideas through physical and virtual outlets [1]. Also, OSPS has partnered with several community organizations to expand learning outside of school. For instance, its partnership with the Art Gallery of Ontario lets students take free tours of unique exhibits with their teachers and access Art Camp to develop their creative minds [2]. Moreover, the school provides numerous opportunities for parents to improve the school's services, such as through volunteering on field trips and organizing community events [2].

Despite the COVID-19 restrictions and the Work to Rule strikes, OSPS as well as the Toronto District School Board provided NLS with incredible support to carry out this project from the audit to remote volunteering. NLS carried out its energy awareness campaign and volunteering plans remotely through virtual education tailored for elementary level (grades 2-5) and intermediate level (grades 6-8) students. Our lessons were focused on energy, building materials, and indoor environment well-being to empower students to practice environmental stewardship. Three themed sets of lessons consisting of videos, handouts, interactive activities, blog posts, and resources for further readings were prepared along with a game. This aligns with our strong belief that learning should be interactive and fun! With the help of OSPS's principal, Michael Walkington, and three of the school's teaching staff, we were able to pass on our lesson materials to the students online to get them engaged. The staff members were enthusiastic about using this material to expand the students' learning and provided us with constructive feedback to improve the material for each set of lessons. Although we were not able to interact with the students in person, we still managed to enrich the educational services at OSPS, and we are grateful for their continuous support.



1.3.1 Our Client Facility

OSPS is located at 18 Orde Street in downtown Toronto. It is surrounded by the midrise University of Toronto buildings, high-rise offices and hospitals, and a small park.

The school site consists of a three-story building with a basement along with a playground and some parking. The basement is primarily used for daycare services, with a daycare office, general purpose rooms, and other accommodations [3]. The first floor, shown in Figure 2, also contains some daycare rooms but is mainly used as space for administration offices, kindergarten classrooms, and art classrooms [3]. The second floor contains more classrooms for older students as well as staff rooms and the school’s technology-integrated library [3]. The third floor contains the remaining classrooms along with a computer lab [3]. The unique feature of this floor is its open roof top patio and open rooftop courtyard. These open spaces were added when the school was first built to serve as a safe learning space for children with tuberculosis, which aligns with the school’s commitment to provide inclusive education [2].

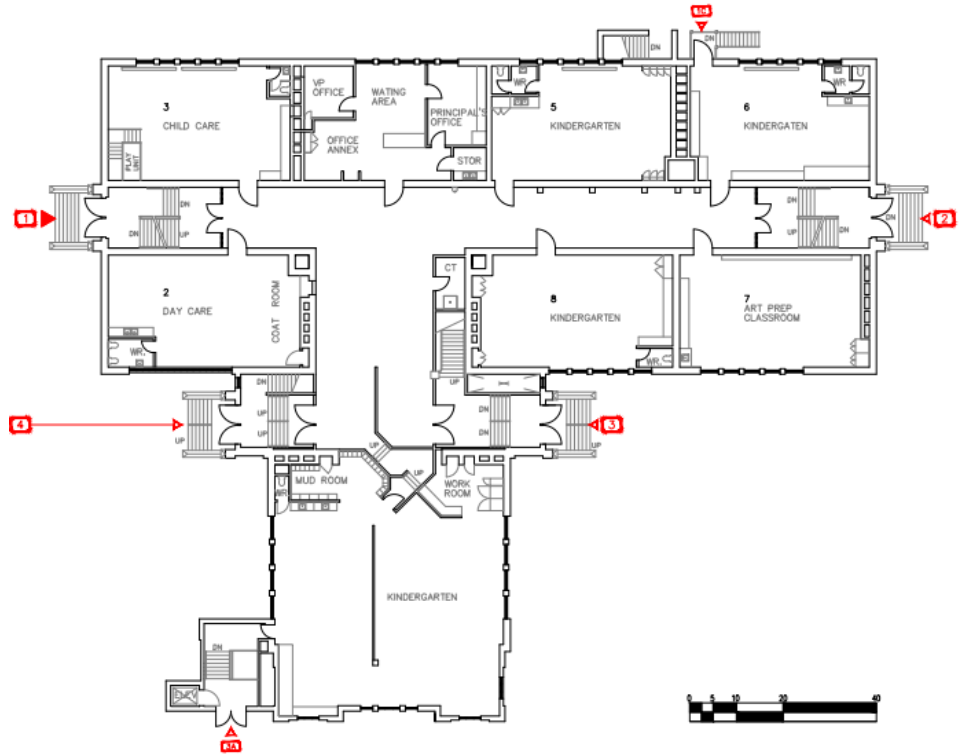
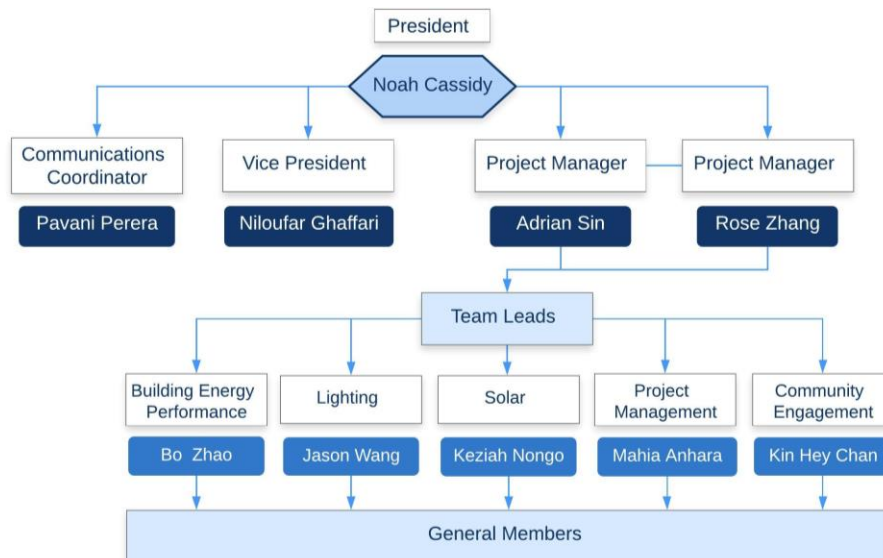

Figure 2 First floor of OSPS [3]

1.4 Our Team



Mahia Anhara

Project Management Team Lead

Mahia Anhara
mahia.anhara@mail.utoronto.ca



Roll in GEC

Project Management Team Lead

Experience

Beacon Utility Contractors Limited / Estimator

May 2019 - August 2019

- Conducted Quantity Take-Offs of the Traffic and Electrical scope of construction projects
- Prepared cost estimates for road construction projects
- Communicated with suppliers and subcontractors to obtain quotes to incorporate into the bids

Volunteer Engineering Experience Program / Project Manager

SEPTEMBER 2018 - APRIL 2019

- Led a team of 5 engineering students to redesign a warehouse layout to improve efficiency
- Researched warehouse optimization options and drafted the alternative floor plan layouts on AutoCAD
- Produced a recommendation report to address safety concerns and inventory management practices

Education

University of Toronto / Civil Engineering

Expected Graduation: 2021

Kin Hey Chan

Community Engagement Team Lead

Kin Hey Chan

kinhey.chan@mail.utoronto.ca



Roll in GEC

Community Engagement Team Lead

Experience

Engineers Without Borders / Indigenous Reconciliation Integration Lead

April 2020 - PRESENT,

- Quantity Take-Offs of the Traffic and Electrical scope of construction projects
- Prepared cost estimates for road construction projects
- Communicated with suppliers and subcontractors to obtain quotes to incorporate into the bids

University of Toronto Hart House / Swim Instructor

Jan 2020 - April 2020

- Design lesson plans and additional help resources

Education

University of Toronto / Civil engineering

Expected Graduation: 2022

Keziah Nongo

Solar Team Lead

Keziah H Nongo
keziahnongo@gmail.com



Roll in GEC

Solar Team Lead
Project Management Team Member

Experience

NSBE UofT / Vice President 2020-2021
MAY 2020- PRESENT

NSBE UofT / Conference Planning Chair 2019-2020
MAY 2019 - MAY 2020

- Coordinate engineering experiences and improved engagement by 13%
- Collaborated as lead in organization of NSBEHacks UofT 2020
- Organized cost/ travel planning for NSBE National Convention

ENGage, Engineering Outreach/ Lead Instructor
SEPTEMBER 2019 - PRESENT

- Instructor position requires adept knowledge in all streams of engineering and STEM
- Created and distributed curriculum for 20 student once a week

2nd Place Rain It In Design Competition Winner, w/ H2Whoa

Ambassador Lead for NSBEHacks 2020

Education

University of Toronto / Civil engineering
Expected Graduation: 2022

Ziyi Wang

Lighting Team Lead

Ziyi Wang

jasonziyi.wang@mail.utoronto.ca



Roll in GEC

Lighting Team Lead
Solar Team Member

Experience

New Oriental Education / Student Tutor

MAY 2019 - PRESENT,

- Tutor international students with English and science courses
- Taught more than 80 classes with over 300 hours of teaching experiences
- Mentor to help international students overcome culture shock

Engineering Strategies and Practices II / Team Coordinator January 2019 - April 2019,

- Designed a sorting method to allow better recycling of residential construction waste
- Ensured that work was distributed fairly, team meetings were productive and deadlines were met

Winner of Denis Flynn Memorial Scholarship (2019)

Winner of U of T Sustainable Case Competition (2020)

Education

University of Toronto / Civil engineering

Expected Graduation: 2022

Bo Zhao

BEP Team Lead

Bo Zhao

bw.zhao@mail.utoronto.ca



Role in GEC

Building Energy Performance Team Lead

Experience

University of Toronto Center for Information Systems in Infrastructure and Construction/ Graphics Designer

AUGUST 2019 - PRESENT,

- Designed and plotted the outlines of three different video presentations using a video editing software called Wondershare Filmora9 explaining the general construction process of a project
- Developed strong interpersonal communication skills to make sure team members and supervisor were satisfied with the graphic design and apart of the design process

Seismic Design Team / Media and Graphics Lead

SEPTEMBER 2019 - APRIL 2020

- Designed a total a 6 different event posters, 2 logos and 2 different team shirt designs
- Improved the sponsorship package layout to attract sponsors for annual competition

Education

University of Toronto / Civil engineering

Expected Graduation: 2023



2 Technical Analysis 1: Energy Efficiency Analysis

2.1 Energy Audit Results

2.1.1 General Electrical System

The average energy consumption of a school of 77,000 ft² within the Toronto District School Board is 373,775 kWh/yr of electricity and 1,359,922 kWh/yr of natural gas [4]. In 2018 and 2019, the average annual total energy consumption of OSPS was 1,430,000 kWh/yr, consisting of 204,000 kWh/yr of electricity and 1,226,000 kWh/yr of natural, as seen in Figure 3. This makes OSPS’s electrical energy and natural gas consumption slightly below the school board’s average.

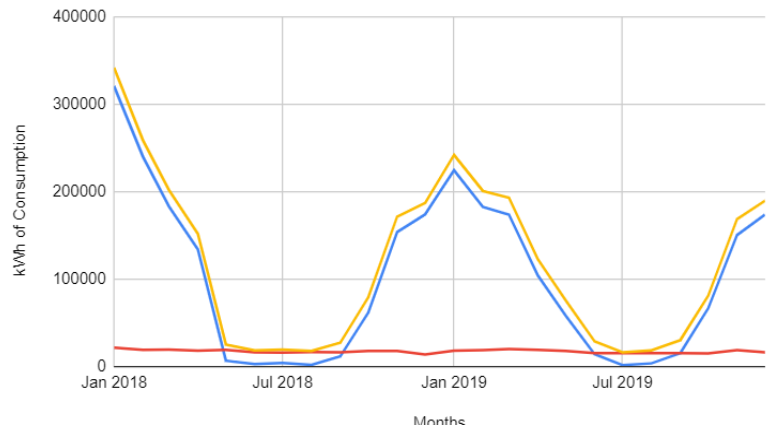

Figure 3 OSPS Energy Consumption in 2018-2019 and 2019-2020

Conducting a building energy audit to learn more about the energy use within the school, the team found that about 16,900 kWh of electricity is used per month, consistently throughout the year. It is used for cooling, lighting and plug loads. Gas consumption ranges from as low as 1,060 kWh in July 2019 to as high as 320,000 kWh in January 2018. The main source of gas use is for space and water heating, leading to the expected rise in consumption during the winter months. Shown in Figure 4 is a summary of the data collected by the team in our energy audit of the facility. We recorded all existing lighting, cooling, and appliances in the building. 39% of the building’s electricity use is for lighting, while 31% is for cooling and 30% is consumed by plug loads. It is important to note that as access was limited to certain areas of the building, accurate estimates of certain systems was prevented.

To meet the building’s heating demand, OSPS uses a natural gas boiler. Throughout the rest of the year, about 6,400 kWh/month, is used. The team expects this value comes mostly from cooking in the school’s kitchen. Interestingly, this value does not decrease significantly in the summer, over summer vacation. This would imply that the public school does not use the kitchen, and the daycare and other programs account for the use of that space. Unfortunately, the building staff were unable to provide confirmation of this. These activities were categorized as “natural gas plug loads” in our analysis.



Overall, 76,400 kWh of natural gas is used for natural gas plug loads and 1,115,300 kWh is used for heating, accounting for 5.3% and 80.5% of total energy consumption, respectively. 60,400 kWh of electrical energy is used for plug loads, 62,200 kWh for cooling, and 79,700 kWh for lighting accounting for 4.2%, 4.3%, and 5.6% of total energy consumption respectively, and seen in Figure 5.

2.1.2 Existing Lighting Fixtures and Controls

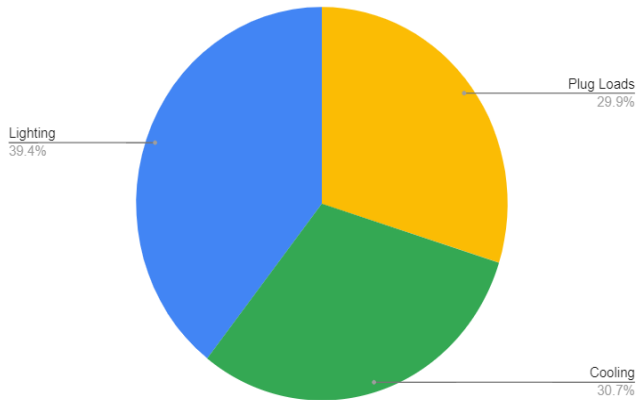

Figure 4 OSPS Total Electricity Breakdown

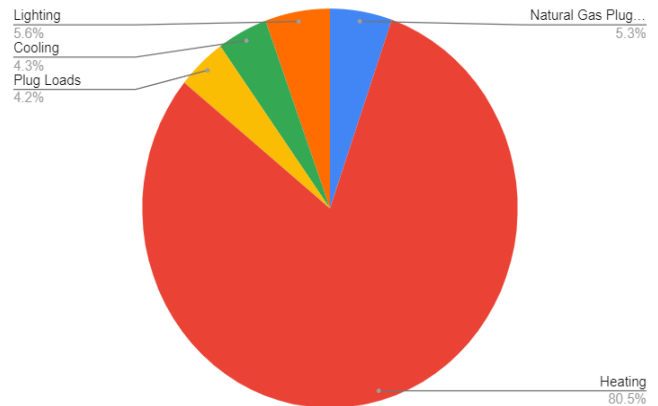

Figure 5 OSPS Total Energy Consumption Breakdown

Data on existing lighting fixtures was gathered during the energy audit. Daily operating hours were decided based on area use. 6.5 operating days per week was assumed for classrooms, childcare rooms and offices while other areas were assumed to operate 7 days per week. While schools usually operate 5 days per week, OSPS hosts a Japanese Language Program on Saturday of each week. Stairwells/Hallways and the library were assumed to have 10 hours of operation daily due to little access to natural light, while classrooms, offices and childcare rooms were assumed to have 8 hours. A total annual energy usage of 79,762 kWh was estimated in Table 1.

T12 lamps are the most prevalent type of bulbs for interior lighting in OSPS, with the next most common being CFL bulbs. Both T12 and CFL lamps are less efficient than LEDs [5]. 177 bulbs out of 1085 bulbs in the school are not working and need to be replaced. All the light switches in the school were manual and binary, which means the lights are operating at their highest capacity while on and are consuming more energy than necessary.

Table 1 Summary Table for Existing Lighting Systems

Location	Light Type	Total Wattage (W)	Daily Operating Hours	Total Weekly Operating Hours	Weekly Energy Use (kWh)
Stairwells and Hallways	CFL	195.0	10.0	70.0	13.7
	T12	5,240.0	10.0	70.0	366.8
Classrooms	T12	21,195.0	8.0	52.0	1,102.1
Offices	T12	3,720.0	8.0	52.0	193.4
Washrooms	CFL	26.0	12.0	84.0	2.2



	T12	1,600.0	12.0	84.0	134.4
Child Care Rooms	T12	3,920.0	8.0	56.0	219.5
Kitchen and Lunchrooms	T12	800.0	4.0	26.0	20.8
Library	T12	4,800.0	10.0	84.0	403.2
Damaged Light	T12	6,600.0	N/A (Varies)	61.0	402.6
	CFL	104.0	N/A (Varies)	80.0	8.3
Weekly Energy Usage (kWh)					2,045.2
ANNUAL ENERGY USAGE (kWh)					79,761.8

2.1.3 HVAC Motor Controls

Equipment specifications were not initially accessible during the audit, so information was obtained from a post-audit inquiries and document retrieval. A natural gas boiler in the basement, with a heating capacity of 6 MMBtu/hr is used to supply the hot water for the networks of ceiling and baseboard radiators within the whole building [6]. Several thermostats are located throughout the building, including one in the office annex, two in the first-floor staircase at the north of the building, two in the northern kindergarten classrooms, and one in a third-floor classroom. The water heaters in the building are also fueled by natural gas. Boiler energy consumption, in volume of natural gas, was provided by the utility company, Enwave, for the whole building. This allowed for the corresponding heat consumption of 1,150,000 kWh to be calculated based on the heat capacity of natural gas.

The building has a central fanning unit from the 1960s for ventilation. Vents and other ventilation equipment were located throughout the building to promote air circulation where needed. In addition, an air filtration machine in the first-floor hallway, although unplugged, was available for use. Portable fans were available on the second floor as well in several offices for use, and overhead fans were observed in the gym. In addition, a fresh air exhaust, kitchen exhaust, and several unit ventilators on the third floor were noted, which suggest a lack of adequate ventilation at this height that must be supplemented by these interventions. As air quality is not the priority of this proposal, and this is noted for the client's benefit but not covered by retrofits. For cooling, there are several window AC units – three in the basement, two on the first floor, and four on the second floor. Toronto's climate has relatively few cooling degree days, and so AC units are not necessary for all rooms.

2.2 Energy Benchmark

Energy Star Portfolio Manager® estimates that OSPS's site and source Energy Use Intensity (EUI) to be 1.38 GJ/m² and 1.57 GJ/m² respectively. It uses natural gas and electrical consumption utility bills of 2018 and 2019, age and square footage of the school, to estimate the values shown in Figure 7. It also estimated that greenhouse gas emissions are about 244.1 metric tonnes of CO₂ per year. These three values (site and source EUI, and CO₂ emissions) are 41% higher than the national median. This finding is the result of the portfolio manager estimating the annual energy consumption for buildings that are similar to OSPS in terms of electricity use, natural gas use, gross floor area and building function.



OSPS also uses 451,200 kWh more for site energy use and 513,300 kWh more for source energy use than the national median for a property of its size. These metrics shows that OSPS is notably worse in energy performance than similar buildings, most likely due to a combination of age of the building and building’s operating equipment. A summary of OSPS’s floor area by function is shown in Figure 6 [7].

Results of Energy Star Portfolio Manager®

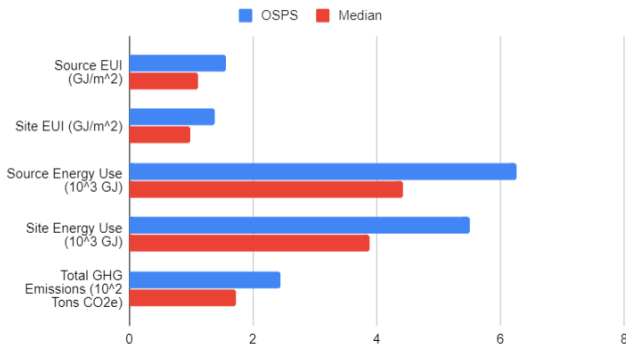

Figure 7 Results of Energy Star Portfolio Manager®

Gross Floor Area of Armour Heights by function

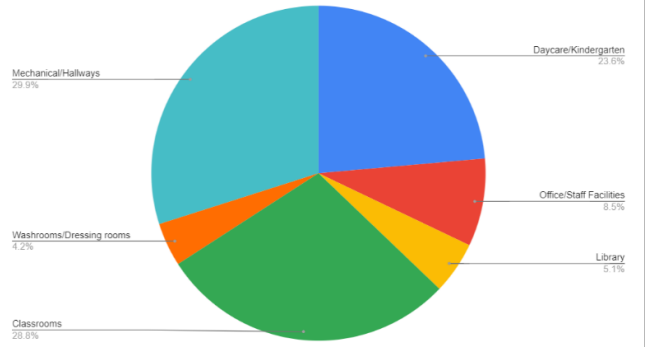

Figure 6 Floor Area Usage of OSPS

2.3 DOE Building Assessment

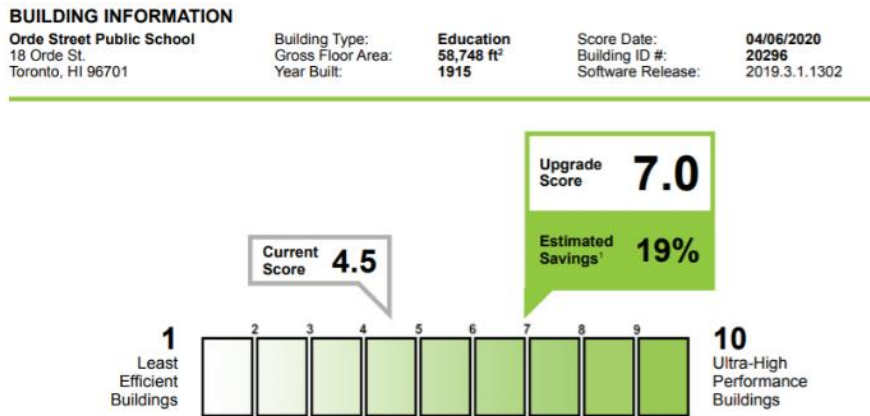

Figure 8 Results of DOE Building Energy Asset Scoring Tool

Using the DOE Building Energy Asset Scoring Tool, the energy performance of this building is rated to be 4.5 out of 10, making it neither an inefficient nor high-performance building. The energy savings potential of OSPS, as estimated by the Tool is 19% and, with the right retrofits, could reach a rating of 7.0 out of 10 as shown in Figure 8. The application, which was developed by the US Department of Energy, generated this energy performance score by considering the building’s overall shape, function/use, types of water heaters, HVAC systems and lighting fixtures.

The DOE tool also generated a report that gave an estimated site and source EUI of 0.61 GJ/m² and 1.77 GJ/m² respectively when converted from kBtu/ft². Although the source EUI noted in the DOE model is similar to the value provided by the Energy Star Portfolio Manager®, the site energy use is substantially less. This difference is because Portfolio Manager works with the utility bills directly, whereas the DOE model estimates the bills from a model of the



building. As a result, the Portfolio Manager provides a more realistic estimate [8]. Retrofit recommendations were also given by the report with focus on new lighting fixtures, HVAC systems, and the building envelope to maximize OSPS's energy saving potential.

2.4 Recommendations

In terms of recommendations of retrofits for OSPS, our retrofit recommendations explore two main areas: windows and OSPS's current HVAC systems. Most windows within OSPS need repairs from framing cracks and a majority of energy consumption goes into heating the school. The HVAC system is also very old (nearly 60 years), thus is a prime candidate for an efficient replacement.

2.4.1 Thermaliner Curtains/Roll-Down Blackout Shades

Eclipse Thermaliner curtains are made up of two layers of fabric that provide significantly more thermal insulation than regular curtains. The back lining is a layer of white foam that can block 98-99% of sunlight, reducing the amount of energy required to cool the room in the summer. Thermaliner curtains can also be used for insulation in the winter, as they are able to reduce up to 14% of heat loss through a single pane window and 66% of heat loss when used with triple pane windows, allowing for more efficient heating in the winter.

Currently, most classrooms use plastic shutter blinds to cover windows. Although they can block light, they do not have significant insulating effects. In order to maximize the use of natural lighting throughout the day, the Thermaliner curtains can be closed by caretakers after school hours to better maintain ambient temperature throughout the building and improve the efficiency of heating and cooling systems [9].

Simple, though rather stark, roll-down blackout shades will keep out sunshine if they are properly fitted to cover the whole window. Hanging blackout curtains are one of the cheapest, easiest-to-install solutions. Blackout curtains are also known as "thermal drapes" for a reason. They are ideal for blocking light and heat from windows that get strong sun.

Blackout curtains and shades will reduce the amount of heat transferred via windows by as much as 24%, keeping the rooms where they are installed cooler in summer and warmer in winter. This will allow for more efficient use of heating and cooling systems [10].

2.4.2 Double Panel and Vinyl Framed Windows

Currently many of OSPS's windows are single-pane with a wooden frame, with about half of the windows being in bad condition – to the point where electric tape is used as insulation to cover the cracks of the older window frames, as seen in Figure 9. Using the U-Factors for various fenestration products in $W/(m^2 \cdot K)$ chart from the American Society of Heating, Refrigerating, and Air-Conditioning Engineers (ASHRAE), it is estimated that a majority of OSPS's windows that have a single-pane with a wooden frame have a U-Factor of $5.58 W/(m^2 \cdot K)$, although are likely to perform worse as they are in bad shape [11].

To reduce heat loss, vinyl frame, double pane windows should be installed to replace the current window system. Compared to a single-glazed window, double-glazed windows can reduce the energy loss through windows by 20-50% [9]. Energy loss can be further reduced with low-emissivity (low-E) coatings installed on the windowpanes, a layer of fine metal that scatters outgoing radiation. The costs to install a double pane window with a vinyl frame are generally between \$2.45 CAD to \$4.67 CAD per square foot [13]. Using the same chart from ASHRAE, double pane windows with a vinyl frame of 13 mm of air space and an e-coating value of 0.2 would have a U-Factor of $2.22 W/(m^2 \cdot K)$. This would save



60% of the heat loss through OSPS's windows. Additionally if OSPS wishes to use a triple glazed window system, with a U-Factor of 1.41-1.74 W/(m²·K) for the same values of air spacing of e-coating, total heat loss from windows can be

Figure 9 Examples of OSPS Windows in Poor Condition



reduced by another 21-36%.

2.4.3 Electric Boiler

The facility is currently served by a natural gas boiler by Cleaver Brooks, model 5 6000 LWV. This model, typical of natural gas boilers, has an efficiency of 85%, although due to its age could be operating at a lower efficiency [6] [14]. The team recommends replacing this boiler with an electric-powered boiler with the same capacity. Electric boilers have an efficiency of 100%, so this switch could decrease energy consumption in the building by up to 473,000 kWh [15]. We recommend another Cleaver Brooks boiler, WB-362. It has a similar capacity and will output 4900 lbs. of steam/hr for 1440 kW.

While the efficiency benefits are obvious, the economic argument for electric boilers is less strong in certain circumstances. Electricity is far more expensive per kW than natural gas in Ontario. In this case, the primary goal is net zero energy use, and the overall savings from the proposal will make up for the more expensive fuel cost of this recommendation. As an additional benefit, an electric boiler combined with the next recommendation – electric water heater – are two major steps towards making the building carbon neutral, another important sustainability goal.

2.4.4 Electric Water Heaters

While the water heater was inaccessible during the audit, from the natural gas bills the team was able to estimate the natural gas usage of the water heater. Switching to an electric model is a major step towards making the building carbon neutral on-site, achieving zero annual carbon emissions. The capital cost of installation is cheaper for an electric water heater, but as electricity is more expensive than natural gas in Ontario, an electric water heater has a higher operational cost. The model that this team recommends is the Rheem Performance Platinum 50 Gal Gas Water Heater [16]. If each person requires 0.4 gallons of hot water at maximum demand and the size of OSPS is about 600 staff and students, 240 gallons of hot water is needed which the five units of the recommended water heater model will provide [17].



2.4.5 AC Unit

According to school caretaking staff, the current air conditioning fan unit has been used since the 1960s, meaning that it is at least 50 years old. Older air conditioning units are significantly less energy efficient compared to newer models and typically have a SEER of less than 6. Modern air conditioning units use 30-50% less energy to produce the same amount of cooling as air conditioners made in the 1970s and using a 10-year newer model can save energy costs by 20-40% [18].

A new air conditioning unit should have a high EER. The 12.5 Ton Daikin Two Speed Central Air Package Unit 3 Phase is a suitable replacement as it is an energy efficient air conditioning unit that achieves an EER of 11 and an IEER of up to 11.2. This will be a significant improvement compared to the current model used by the building. This unit also features SmartCoil technology which provides efficient heat transfer and allows less refrigerant to be used [19].

Using the Energy Star recommendations on cooling capacity relative to the square footage of the room, the team estimates that 758,000 BTUs or 62.5 tons of cooling capacity is needed per hour to fully cool the school for the spaces that do not contain a windowed AC unit [20][21]. Thus, the team recommends installing five units of the recommended AC unit model.

2.5 Contributions to Net-Zero and Return on Investment

Installing an electric boiler and water heater provides the most significant savings in heating by reducing the annual total heating demand by 526,000 kWh or 49,856 m³ of natural gas/year [22][23]. Changing the natural gas water heater and boiler to electrical will allow OSPS to reach net-zero as the consumption of natural gas cannot be sustainable whereas electricity is via the installation of solar panels in section 4. Investing in new AC units will reduce cooling demands by 40% in electrical consumption of cooling, or 25,000 kWh of electricity [24]. While this retrofit gives one of the smallest quantities of energy savings, net zero is a high standard, which requires all aspects to be met.

Installing double-pane windows with vinyl siding will reduce the heat loss from windows by 50% or 257,400 kWh of natural gas [25]. The retrofit with Thermaliner curtains will also reduce the heat loss from windows by a further 25%, allowing 107,000 kWh of natural gas to be saved as well [26]. The window improvements in total provide additional savings of 364,400 kWh of natural gas per year in order to allow OSPS to reach net zero energy, and finally improves on the poor conditions that the previous window system was in as shown in Figure 9.

Overall, the team's recommendations achieve a total energy reduction of 915,400 kWh/year, leaving the facility with a final energy use of 514,700 kWh/year after improved building performance, a 64% reduction. The price of natural gas in Ontario is approximately \$0.079/m³ and the price of electricity is \$0.125/kWh, therefore the retrofits will cost a total of \$132,485 [23][24]. The annual savings of \$9,792 CAD provide a payback period of 13.5 years. The capital costs, annual energy savings, and annual cost savings are summarized in Table 2.

After a lighting retrofit and installing a solar array, as described in the next sections, the total energy use of the school is reduced to 284,000 kWh/year, a reduction of 80%. Should the school wish to achieve net zero, there are a few options it could explore. The least disruptive would be buying time on a wind farm in Ontario. This essentially means financing the operations of a set of wind turbines to produce clean energy offsite. With the lack of space available in downtown Toronto, this is an important alternative for buildings seeking to achieve net zero energy use across all activities.

To make up the last 20% of their energy bill, the school could also investigate more disruptive solutions. A geothermal energy system is an expensive on-site power generation option. Improving the enclosure with increased insulation and



better air sealing would provide significant benefit to the total heating load of the school. Unfortunately, without significant testing, this value is nearly impossible to quantify, and thus was not investigated in this report.

Table 2 Summary of Building Performance Retrofit Savings

Retrofit	Capital Cost (CAD)	Energy Savings (kWh/yr)	% Total Energy Savings/yr	Simple Payback Period (yrs)	Total Annual Savings (CAD)
Boiler Retrofit	62,170 [15][22]	473,000 (44,834 m ³)	33	17.6	3,542
Water Heater Retrofit	5,605 [15]	53,000 (5,024 m ³)	3.7	14.1	397
AC Retrofit	37,750 [19]	25,000	1.7	12.1	3,125
Vinyl Window Retrofit	24,000 [27]	257,400 (24,398 m ³)	18	12.5	1,927
Thermaliner Curtains	2,960 [28]	107,000 (10,142 m ³)	7.6	3.7	801
TOTAL	132,485	915,400	64	13.5	9,792

3 Technical Analysis 2: Lighting Retrofit

3.1 Existing Lighting System

Lighting accounts for about 20% of the energy consumption in K-12 Schools in Canada [29]. Lighting retrofits can lead to lower energy consumption and allow for an improved visual environment.

At Orde Street Public School, the lights operate for about 10 hours, on average. The building’s current lighting conditions were analyzed by gathering the type of light bulbs and the lux reading of all areas in the building. The lux readings were compared to the Illuminating Engineering Society of North America (IESNA) standard to determine if they meet the recommended lux range. The areas with a lower lux reading than the standard were selected; their fixtures will be replaced by the proposed solutions (See Table 3 for the selected rooms). Low lux readings imply that there is insufficient illumination in the rooms. In a school, poor lighting can affect the productivity and quality of work of students, and it can also be a health hazard as students have to strain their eyes to see [30]. T12 lamps are the most prevalent type of bulbs for interior lighting, with the next most common being CFL bulbs. Both T12 and CFL bulbs are known to be inefficient [31]. In addition, about 177 bulbs out of a total of 1085 bulbs in the school are not working and need to be replaced. Furthermore, all the light switches in the school are manual, which means the lights are operating at their highest output throughout the day and consuming more energy unnecessarily.

Table 3 Rooms Below Recommended Light Level Range of IESNA

Room	Room Type Based on IESNA Lighting Handbook	Average Current Light Level (lux)	Recommended Light Level Range (lux)
Basement - Room 28 (office)	Office - Open	281.0	300-500
2nd Floor - Library	Library - Reading/Studying	247.0	300-500



1st Floor - Room 3	Classroom - General	281.0	300-500
2nd Floor - Room 17	Classroom - General	97.0	300-500
3rd Floor - Room 24	Classroom - General	268.0	300-500

3.2 Proposed Lighting Retrofits

3.2.1 Recommendation 1: LED Replacement

NLS recommends that all T12 and CFL lights in the school be replaced with LEDs. For the same amount of electricity usage, LED lights can provide 33% more brightness than T12s and CFL bulbs, therefore, LEDs lead to more energy savings as they can be dimmed to consume less energy [31]. Also, LEDs will help brighten the rooms which are currently below the recommended minimum light level without increasing energy usage. Although LED bulbs have a higher capital cost, they also have a longer lifespan [31]. This means the bulbs will not burn out as frequently as T12s and CFLs, leading to savings in replacement costs.

LED replacement of 16 W and 12 W is recommended for T12 bulbs and CFL bulbs, respectively. The replacement products must have dimming control so that they are compatible with our dimming switch recommendation in section 3.2.3. In addition, the bulbs shall not require replacement of fixtures, ballasts, and lamp holders, in order to simplify the LED replacement process. Based on these criteria, the recommended product for T12 replacement is Toggled's 48 inch, 16 W Dimmable Linear LED Tube Light Bulb, and the CFL replacement is EcoSmart's 12W BR20 Dimmable Energy Star LED Light Bulb [32] [33].

3.2.2 Recommendation 2: Light Shelf

Most of the classrooms have large windows that occupy almost half of the exterior wall. The illuminance close to the windows can reach as high as 1050 lux in the afternoon with lights turned off. Whereas the areas that are far from the window can be as low as 0 lux. The low brightness in the classrooms means the rooms still require artificial lighting. Light shelf is one possible solution for energy efficient uniform illumination. The upper surface of the light shelf is reflective to direct the sunlight into the room [34] and the ceiling provides additional light diffusion, as demonstrated in Figure 10. Additionally, the light shelf reflects artificial light. Lighting uniformity is enhanced by diffusing natural and artificial light. This will reduce the number of light fixtures and overall energy consumption. Moreover, the light shelf reduces the glare near the window caused by direct sunlight [35]. This enhances occupant comfort and productivity [34].



Figure 10 Example of a Light Shelf

Light shelves should be installed in rooms that receive sufficient sunlight to be effective. Based on the shading analysis of the building, light shelves should be installed in all the rooms from the first to the third floor that face south or west. During installation, the angle of tilt of the light shelves directly affects the amount of light reflected. A horizontal light shelf reduces the light level required by 10% to 20% in most of the room, and a 30° downward-tilted shelf reduces the light level required by 30% to 40% [36]. However, a downward-tilted light shelf could reflect sunlight into human eyes and cause glare. As a result, the



angle of tilt should be determined based on the height of the window relative to the floor, the size of the shelf, and the active area of occupants to maximize energy savings and minimize glare.

The product recommended is InLighten Interior Light Shelf which can accommodate various sizes of windows and angles of tilt [37]. The shelves are made of aluminum composite which is light in weight and can minimize maintenance efforts. The cost of the light shelf is estimated to be \$100 CAD per window [37]. By counting the number of windows that face eligible directions, the total cost of the shelves is approximately \$9,300 CAD for 93 windows.

3.2.3 Recommendation 3: Dimmer Switch

Each classroom uses manual switches to control about twenty light fixtures. The school can benefit from dimmer switches, which enables the users to adjust the brightness of the light fixtures [38]. For example, during a sunny day, the classroom may utilize the natural sunlight with adjusted brightness of artificial light to compensate. Unlike manual switches that always use 100% power, the energy output can be controlled by dimmer switches. Thus, reducing energy consumption and prolonging the bulb's life span by reducing the current passing through it [38].

The dimmer switches can be purchased from Home Depot. One suitable type is the Lutron Skylark Contour C.L Dimmer Switch at a cost of \$23.97 CAD [39]. It is applicable for a variety of dimmable LED bulbs. The switch has a rocker switch to turn on and off the light, and a slider to dim the lights. Moreover, it can control up to 17 light bulbs [39]. Each classroom on average, would require two to three dimmer switches.

3.3 Ceiling Plan

Figure 11 below demonstrates the proposed location of the light fixtures. The location and number of fixtures are identical to the existing ones. As one can add or remove light bulbs to reach the optimal brightness from artificial lights, light fixtures are unnecessary to be adjusted considering the renovation cost. Most of the fixtures contain the recommended LED bulbs as described in section 3.2.1.

Figure 12 illustrates the proposed location of the control switches in each room. Overall, they will be located next to the door. The number of the switches depends on the light bulbs in each room. The recommended Lutron Skylark Contour C.L Dimmer Switch can control up to 17 light bulbs [39]. Thus, most classrooms have two dimmer switches, smaller rooms have one switch, and the largest classroom has three switches.

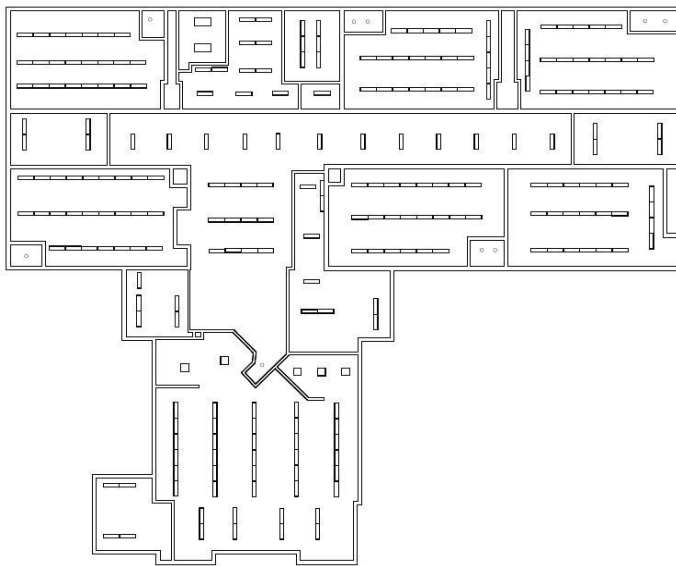

Figure 11 Reflected Ceiling Plan for the First Floor

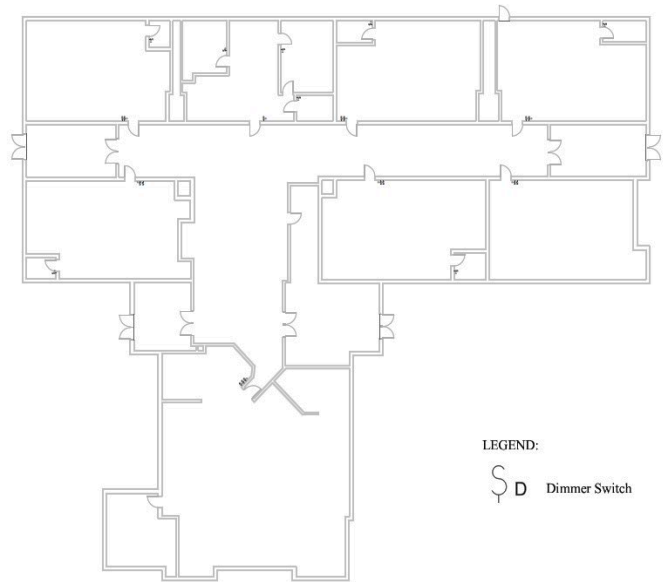

Figure 12 Dimmer Switch Control Illustration of First Floor

3.4 Photometric Analysis Drawing

Light is captured by the retina of human eyes and the received information is directly transmitted to the nervous system, hence different light levels directly affect the occupant's mental and physical health [40]. Over illumination results in glare into the eyes and can cause eye fatigue and retinal degeneration [40]. On the other hand, insufficient illumination can cause headaches, difficulty to see objects and even depression [41]. As the occupants of the rooms are mostly children, light levels should be appropriate to avoid potential safety issues.

Since three rooms were selected for the ceiling plan, Figure 13, Figure 14 and Figure 15 below contain the photometric analysis drawings for those rooms after the retrofits of LED lights. The drawings show that the illuminances of the rooms are approximately 50% higher than the IES illuminance recommendations (300-500 lux). The floors are especially bright as they face the fixtures. However, this analysis is made without the dimmer switches. Therefore, occupants can adjust the brightness of the lights based on different weathers and time to avoid glare.

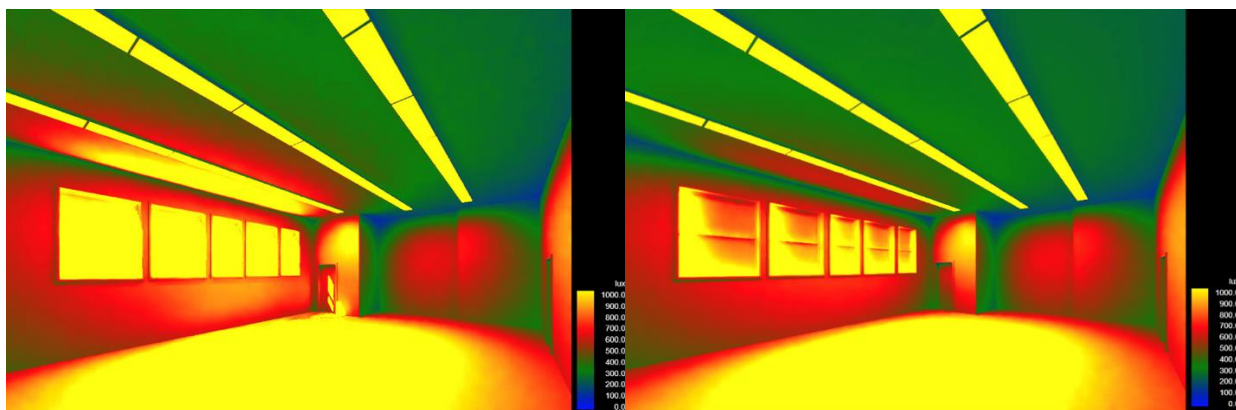

Figure 13 Photometric Analysis Drawing of Room 3 with LED Lights. 9am on the left, 9pm on the right.

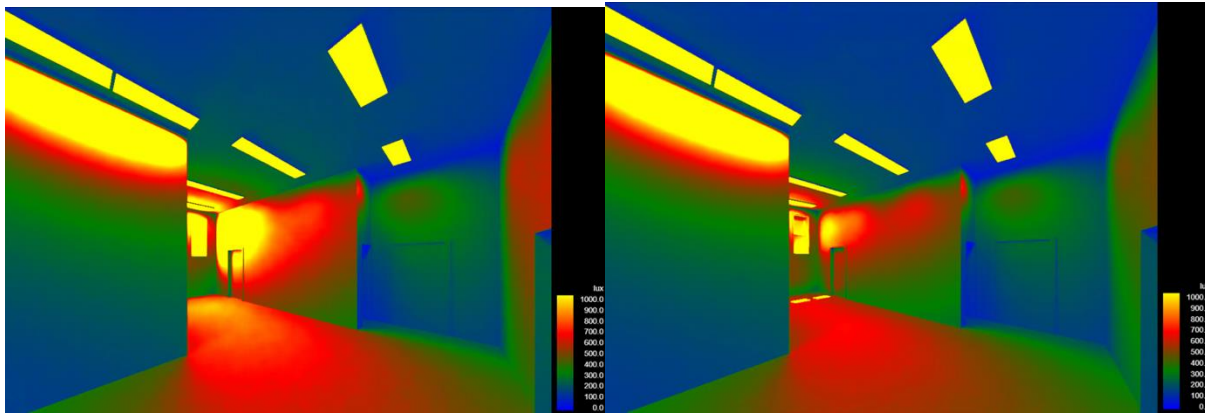

Figure 14 Photometric Analysis Drawing of the Main Office with LED Lights. 9am on the left, 9pm on the right.

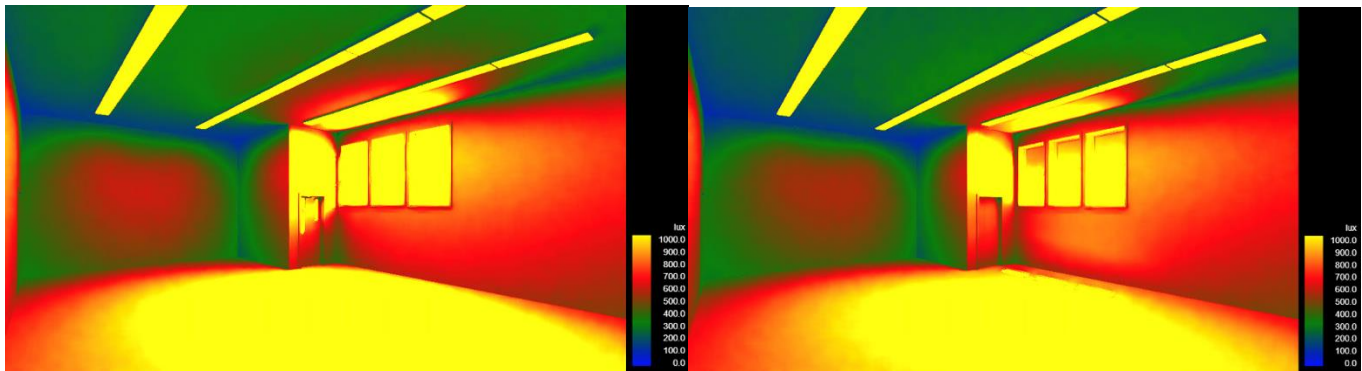

Figure 15 Photometric Analysis Drawing of Room 5 with LED Lights. 9am on the left, 9pm on the right.

3.5 Return on Investment Report

The T12 replacements cost \$10 CAD per bulb, whereas the CFL replacements cost \$3.5 CAD per bulb [32] [33]. Since all existing T12 and CFL bulbs will be replaced, 1085 bulbs will need to be changed, which will bring the capital cost of LED replacements to approximately \$10,400 CAD. Assuming that the cost of electricity is \$0.125/kWh this retrofit will lead to electricity cost savings of about \$5,857 CAD. In addition, there will be a 46,857 kWh/year reduction in energy consumption. The payback period for LED replacements will be 1.78 years.

Dimmer switches may cut the electricity consumption by 20% over time if dimming the lights by 25% during the day [42]. As the total electricity consumption is 79,762 kWh, estimated electricity saving from the dimmer switch will be 15,952 kWh/ year. According to the existing number of light fixtures, 91 manual switches should be upgraded to dimmer switches. Assuming that it takes 0.5 hours to install a dimmer switch, and the hourly wage of an electrician in Toronto is \$45 CAD, the labour cost to install 91 dimmer switches will be \$2,048 CAD [43]. Along with the cost of \$2,465 CAD for dimmer switches, the capital cost for this solution is \$4,232 CAD [39]. Assuming electricity costs \$0.125 CAD per kWh, the payback period for this retrofit is 2.12 years [44].

Installing light shelves can reduce the electricity use by 10% - 40% based on the angle of tilt of the shelf [36]. As this method is only applicable to rooms that have sufficient exposure to sunlight, the basement is not considered. Taking an average of 25% as the total energy reduction with light shelves and the current electricity use of 54,411 kWh (without the basement), the estimated energy saved by the light shelves is 13,600 kWh/yr.



Assuming that it takes 0.5 hours to install a light shelf and the hourly labour cost is \$35 CAD, the total installation cost is \$1,628 CAD for 93 light shelves. Adding the material cost of \$9,300 CAD, the final capital cost of light shelves is \$10,928. Assuming electricity costs \$0.125 per kWh, the payback period of this retrofit is 6.43 years [44]. Although this period is slightly longer than the other solutions, no additional electricity input would be required for this method after installation, a benefit in long-term usage.

3.6 Contributions to Net Zero

Table 4 Financial Summary

Retrofit	Capital Cost (CAD)	Electricity Savings (kWh/yr)	% Electricity Savings/yr	Simple Payback Period (yrs)	Total Annual Savings (CAD)
LED Replacements	10,435	46,857	60	1.78	5,857
Dimmer Switches	4,230	15,962	20	2.12	1,995
Light Shelves	10,930	13,600	25	6.43	1,700
TOTAL	25,595	76,419			9,552

NLS recommends proceeding with the installation of dimmer switches, LED replacements of T12 and CFL bulbs, and light shelves. These retrofits will bring electricity savings up to 60% annually. The payback period can be as short as 1.71 years. The More details about financial planning and true payback period calculation will be presented in Section 5.



4 Technical Analysis 3: Solar Energy System

4.1 Existing Conditions

OSPS is surrounded by relatively tall buildings on all four sides. Figure 16 illustrates the surrounding conditions of OSPS. To the east of the school is the commercial center and to the west of the school is the University of Toronto Exam Centre [45]. Since both buildings cast shadows onto the school, buildings facades will receive limited solar light. Furthermore, excluding the main building, most of the site is used for the playground; the remaining is used for parking and green space. Therefore, this ground floor location is not suitable for solar panel installation due to human activity and limited sunlight.

4.1.1 Selected Location

The recommendation is to install PV panels on the rooftop. It has large, unoccupied, space for PV panel installation (see Figure 17), and also receives the most sunshine compared to the balconies and parking lot. The PV system will be designed to fill all unoccupied roof space, within the limits of existing regulations. This maximizes electricity generation to offset the 1.43 million kWh consumed in 2018 and 2019 (Section 2) for lighting, plug loads and the HVAC system.

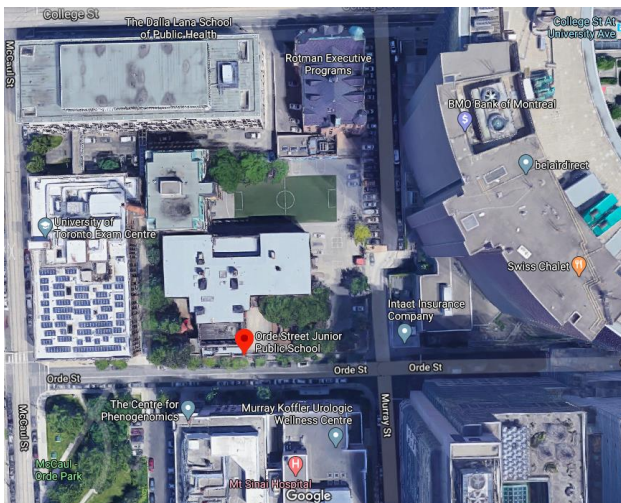

Figure 16 Plan View of OSPS and its Surroundings

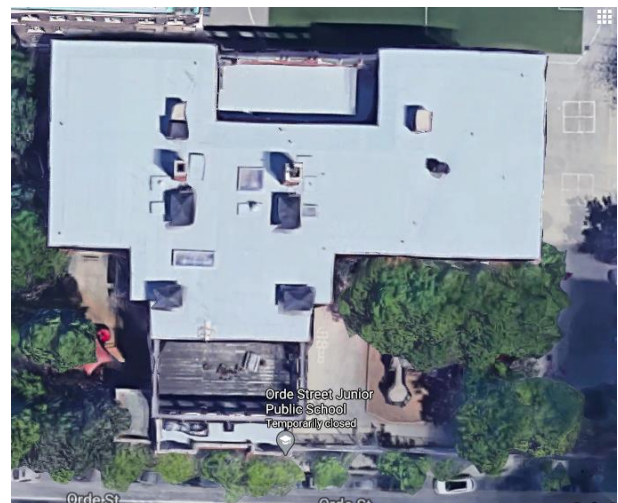

Figure 17 Close-up Roof Plan View of OSPS

4.2 Connection Details

A grid-direct system is recommended for Orde Street Junior Public School due to its high performance. Since the school is only occupied during the daytime, the electricity generated by the solar panels should be sufficient to power the building (i.e. a battery bank to provide electricity at night would not be needed). Additionally, the surplus electricity generated by the panels could be sent to the grid and distributed to other buildings, though Toronto Hydro will not pay for surplus electricity [46].



Table 5 Summary of Connection Details

System	Description	Advantage	Disadvantage
Grid-Direct	The energy generated by the panels is sent to the grid by an inverter, then electricity is extracted from the grid	<ul style="list-style-type: none"> - A battery is not required - Simple & inexpensive installation - Electricity from the grid can be used if solar panels do not generate enough power 	<ul style="list-style-type: none"> - Does not include storage, therefore does not work when there is a power outage
Grid-Interactive	A battery is used to store electricity from the panels, it feeds to the grid with an inverter when needed	<ul style="list-style-type: none"> - High stability as the battery acts as a backup in a power outage - The battery has a longer life than the off-grid system since it only acts as a backup 	<ul style="list-style-type: none"> - More expensive than a grid-direct system as a battery is required
Off-Grid	Electricity generated by the panels directly feeds to the building by using a charge controller, an inverter, and a battery bank	<ul style="list-style-type: none"> - Function independently from the grid - Can function during a power outage 	<ul style="list-style-type: none"> - No supplement if panels do not provide enough electricity - Complex & expensive system - Excess electricity is wasted instead of distributed to other places

4.3 Shading Studies

4.3.1 Shading Analysis

To conduct a shading study, the team utilized DIVA, ArchSim simulation programs and Rhinoceros 3D to model the school, surrounding buildings and potential PV system designs. In the study, NLS found that the neighboring office towers caused the most significant amount of shading on the west side of the roof.

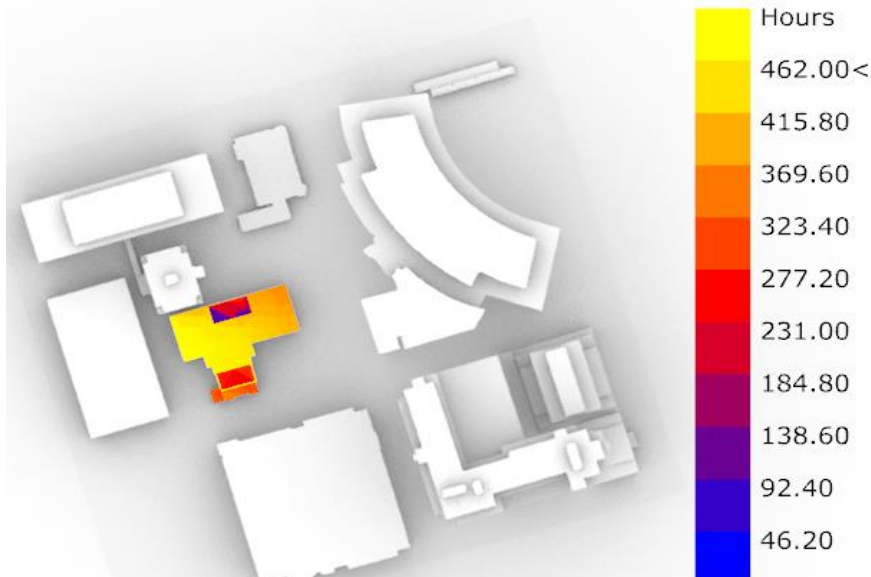

Figure 18 Annual Daylight Hours Visualized on OSPS Roof



Figure 18 presents annual daylight hours visualized on the roof in a color gradient. The colors represent the number of daylight hours each area of the roof receives annually on the 7th, 14th, 21st, and 28th of each month.

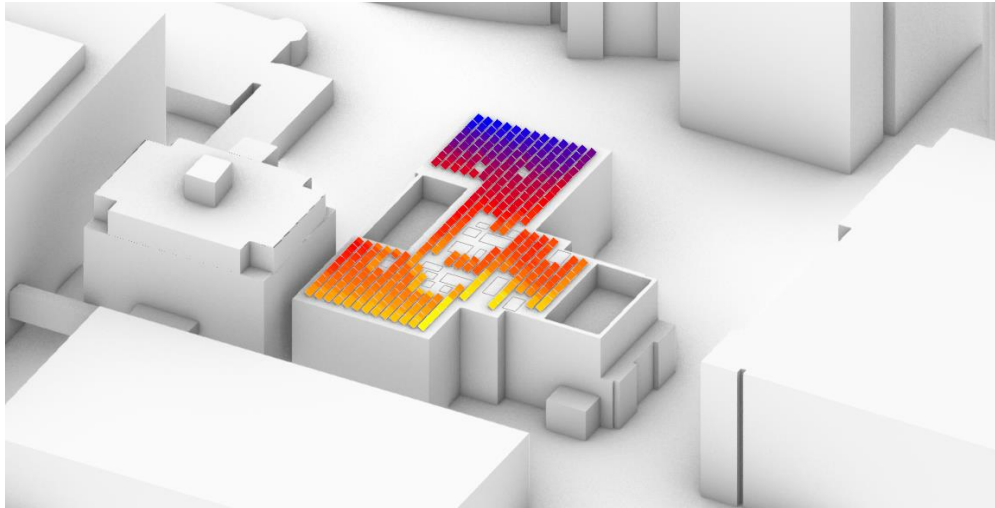

Figure 19 Sunlight Hours Demonstrated on Potential PV Panel System Configuration

Depending on the time of the year, the number of shaded solar panels will differ. The visualization in Figure 19 shows the south-west side of the roof receives the most hours of sunlight throughout a 12-month period. The roof-top courtyard spaces on the third floor receive the least, and so would not be an appropriate location for any solar panels. The north-west corner of the roof receives less sunlight hours in comparison to the rest of the roof. This indicates that the neighboring office tower to the north-west creates the most shading onto the roof.

4.3.2 PV Tilt Recommendation

In a second simulation, the team extracted potential electricity production for a PV system with panels tilted at 3 different angles - 30 degrees, 35 degrees and 45 degrees (Refer to Table 6). NLS proposes to orient the panels south at a 35 degree tilt in order to accommodate an appropriate number of solar panels, while also leave space for servicing, avoiding self-shading between panels, and following the Ontario Building Code requirement of a 1.2 meter setback between the system and the edge of the roof [47]. An adequate tilt is necessary to ensure sunlight is received by the panels during the high sun angle of winter months, which is the season during which the school is in its highest use.

Table 6 Annual Electricity Production for Each Potential Number of PV Panels

	30° Tilt (296 Solar Panels)	35° Tilt (317 Solar Panels)	40° Tilt (740 Solar Panels)
Annual Electricity Production (kWh)	114,418.94	119,778.63	295,327.32

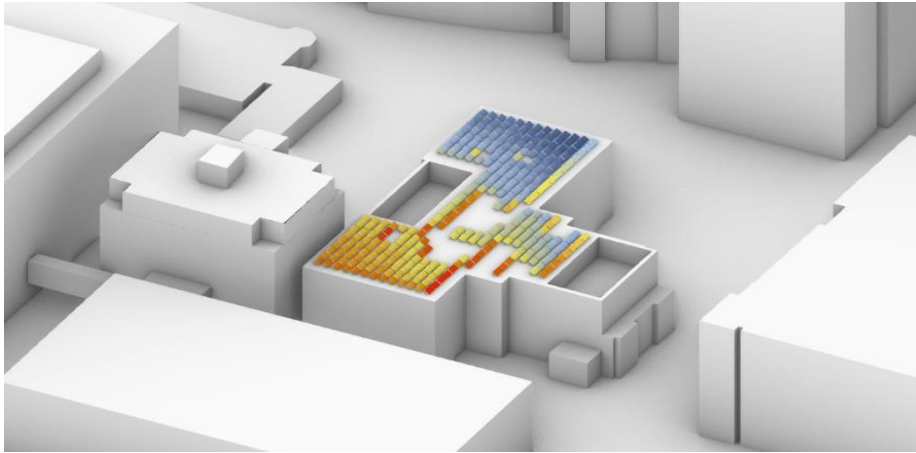

Figure 20 Electricity Production Visualized on PV System with 35 Degree Tilt Panels

Snow removal and rapid weather changes are common to Ontario. The 35-degree system in Figure 20 is selected to allow for minimum maintenance costs due to snow removal, and providing sufficient power in different weather conditions [48].

4.4 Component Selection

4.4.1 Panels

OSPS's large roof area allows efficiency to be sacrificed for lower cost. In Toronto's climate, panels need to be durable and snow load bearing. In a comparison between monocrystalline and polycrystalline solar panels [49][50], it is determined that a monocrystalline panel is a better choice because of its energy output efficiency and longer lifespan. The recommended solar panel is from Canadian Solar HiDM CS1H-320MS 320 W. The panel has a better shading tolerance compared to other panels [51]. Its capability for reasonable snow and wind load is ideal for Toronto's climate [52]. Despite its lower power output than the 330 W model and modulus efficiency of 18.98%, its cost is optimal for a large array of solar panels [52][53]. The cost for 317 panels is \$89,711 CAD.

4.4.2 Ballasted Flat Roof Racking System

A ballasted racking system is a non-invasive system that allows for PV panels to be secured on the flat roof without permanent attachments. This means the system can be added to, or customized, more easily in the future. Since it requires less installation material, its capital cost, labor requirement, and installation duration will be reduced. This system is more cost-efficient compared to an attached mounting system [54]. The team recommended PR2 - Ballasted Flat Roof System from Polar Racking Inc. This racking system is easy and simple for installation as it only comes with three major components; the runners, cross-members, and wind deflectors [55]. In addition, the company had installed mounting systems in a variety of school boards in Ontario previously, including Toronto District School Board [56]. The estimated ballasted system cost for this project is \$10,144 CAD.

4.4.3 Combiner Box

A combiner box is used to connect the solar arrays and allow the output to flow in series. Therefore, the output from the combiner box would have a constant current and voltage, allowing users to better control the input power going into the inverter. All solar panels in each solar array are connected in series and the PV system contains 18 parallel arrays. ECO-WORTHY 6 String PV Combiner Box is selected as it can combine 6 arrays, thus a total of 3 combiner boxes are required with a cost of \$669 CAD [57].



4.4.4 Inverter

An inverter is used to convert DC power from solar panels to AC power for the grid and appliances. The most common and least expensive type is a string inverter, which collects all strings of solar panels into one inverter. Micro inverters are also available and are installed on each solar panel [58]. Since the proposed solution will result in a relatively large system, a string inverter is selected due to its economic advantage in a larger solar system and easier installation compared to that of microinverters. After analyzing the cost-benefit ratio, output power, and component compatibility to the system, the SMA Sunny TriPower 12000TL-US-10 Inverter is chosen [59]. It outputs 12,000 W at 120V AC with a 98% efficiency. With a 170-kW system, 14 inverters will be needed at a cost of \$33,244 CAD.

4.5 Schematic Drawing of PV System

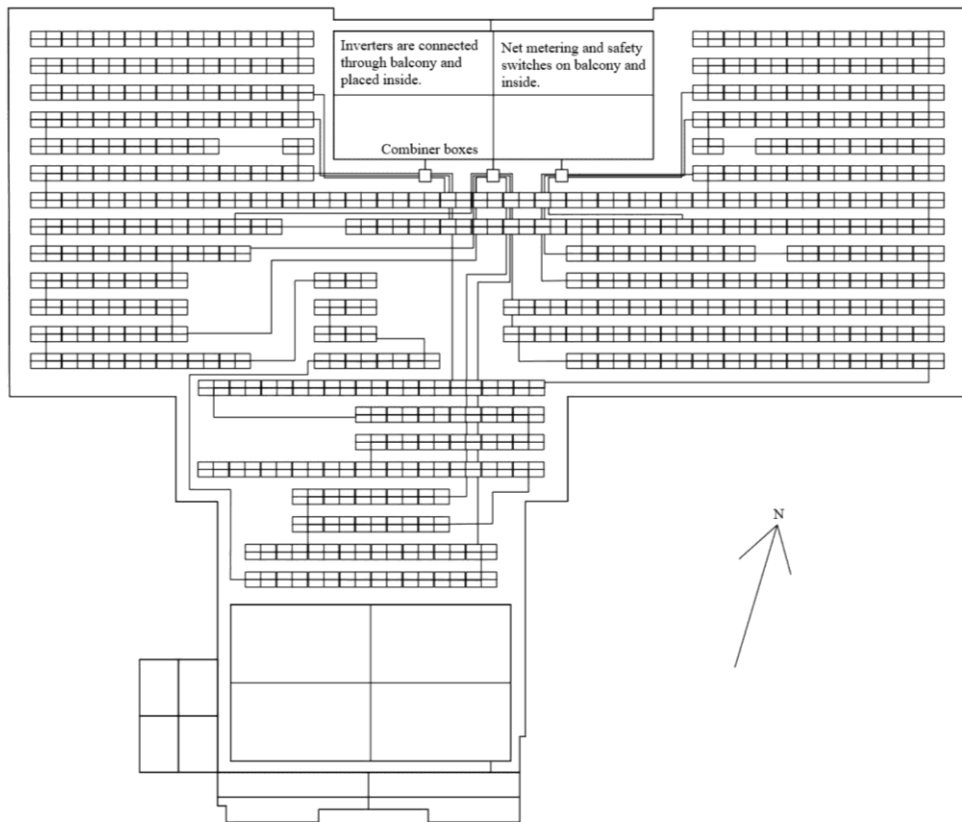

Figure 21 PV System Schematic Diagram

The schematic drawing shown in Figure 21 depicts the arrangement of panels for the entire system. The system features a total of 317, 35-degree tilt PV panels, 3 combiner boxes, and inverters with 16 AWG gauge wiring throughout [60]. All features are sufficient for the requirements of the system's capacity. The spacing between panels is sufficient to prevent shading by adjacent panels and allow for proper maintenance throughout the year [61]. The panels are placed 1.2 m from the edge in accordance with Ontario regulations [47].



4.5.1 Three-Line Diagram

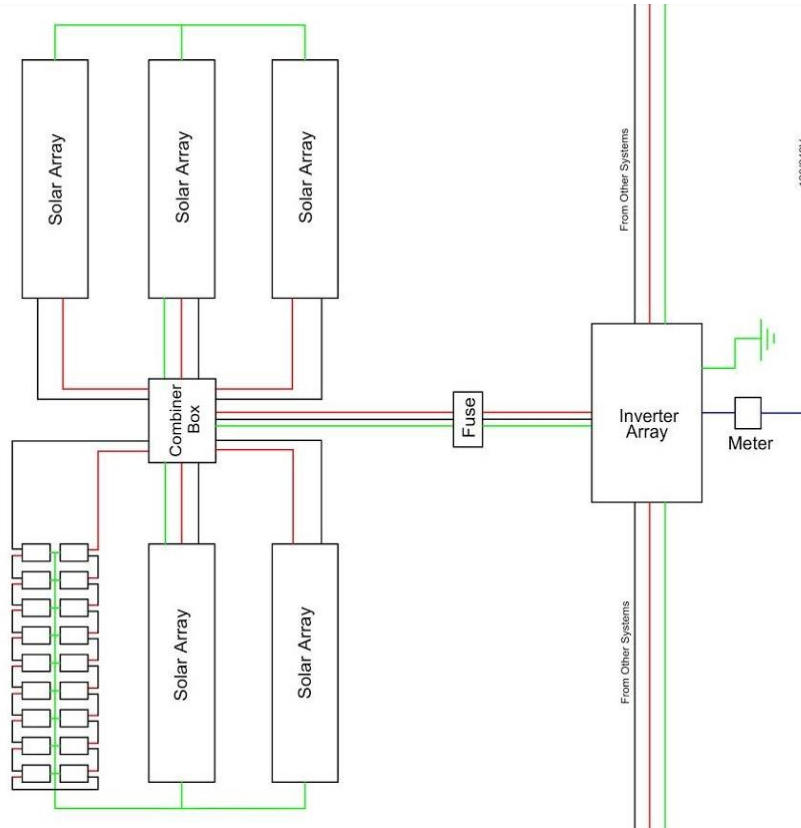

Figure 22 Three Line Diagram of Repeated PV System Connection

The PV system has 3 main combiner boxes consisting of 6 strings, of up to 18 panels, to a total of 317 panels. The general repeated sections are shown above in Figure 22. The entire system is attached to the same central inverter array, consisting of 14 inverters in total. All component quantities are appropriate to handle the load sent from all PV arrays to the central system [62].

4.6 Solar Energy Summary

4.6.1 Cost Summary

Overall, the estimated total upfront cost for the solar system is \$149,873 CAD, which includes the material and installation cost of \$146,913 CAD and maintenance and operations cost of \$2960. The implementation cost consists of 317 PV panels and mounting systems, 14 inverters and 3 combiner boxes, along with the corresponding installation cost.

Assuming an electricity cost of \$0.125/kWh, implementing the system would save \$14,970 of electricity cost [63]. Since the total cost of the PV system is \$146,915 CAD the period for positive cash flow is about 9 years and 8 months [64].

4.6.2 System Challenges

One common challenge in the PV solar system maintenance is the regular snow and ice removal in the winter [65]. Due to the climate in Toronto, heavy snow covering causes a decrease in energy production and cost effectiveness [66]. Salt is not a good option for snow and ice removal because it is corrosive. With the proposed system consisting of 317 solar



panels, snow clearing will be a challenge. One solution is a shielding and drainage roof plan, further analysis of this solution is not possible currently [67].

4.6.3 Incentives and Rebates

There are limited incentives provided by the government for non-residential properties. There are none currently that apply to the OSPS project. However, Hydro One Net-metering is a policy allowing electricity consumers to earn credits towards their electricity cost by sending electricity generated through Renewable Energy Technologies (RETs) back to Hydro One [68]. Excess generation credits can be carried forward for 12 consecutive months [69].

4.6.4 Net-Zero Recommendation

The proposed solar system produces 119,800 kWh annually. The electricity generated is below the total equivalent electricity consumed (1,430,000 kWh), meaning OSPS will not be a net zero building with the recommended system. Without the proposed project retrofits the PV system would require 3512 more selected solar panels or 1124 kW of power to reach net zero. With the proposed project retrofits the PV system would require 789 selected solar panels or 252 kW of power. To achieve net zero after implementing all other recommendations, the system would need to be nearly 4 times as large and produce over 403,800 kWh annually.

4.6.5 CO₂ Pollution Analysis

Based on the CO₂ factor of the energy mix of Ontario, Canada (31g CO₂ eq/kWh), and the GHG emissions added from operating and maintaining the PV system (55 g CO₂ eq/kWh), the proposed system will eliminate 3713 kg (4.1 US tons) of CO₂ eq. annually and 92,800 kg (102.3 US tons) CO₂ eq. across a 25 year timeframe [70][71]. That is the equivalent of the CO₂ production of 4 average Canadian households over the course of the system's lifetime [72].

5 Schematic Estimate, Schedule, and Finance Plan

5.1 Cost Estimate

The preliminary cost estimate for the energy retrofits project is presented in Figure 23. This estimate accounts for materials, labor costs, indirect and general expenses of the project. The total construction cost is estimated to be approximately \$445,950 CAD and the annual maintenance cost is estimated to be \$2960 CAD. The hourly rate of labor is obtained from the City of Toronto's Current Fair Wage Schedule for ICI work and the Government of Canada's Job Bank data [43][73]. Various cost estimating guides were referred to determine the unit production time [74].

General conditions and assumptions of the estimate are as follows:

1. The building maintenance staff will be responsible for installing Thermaliner curtains and replacing the LED lights during their regular salaried hours.
2. Workers who will be working on weekends will be paid overtime wage, which is double the regular hourly wage.
3. Municipal inspection and permits will be required for solar installation and mobile crane set up [75].

5.2 Scheduling

In OSPS, there are no school activities for Kindergarten to Grade 7 students during the months of July and August due to summer vacation, however, the daycare center operates throughout the year. In addition, children's language classes are held on Saturdays during the academic year. The project schedule has been created to meet the goal of minimizing disruption to the school's activities and prioritizing safety. To meet these criteria, most of the construction phase has been scheduled to occur during July and August, when the school is least occupied. The proposed schedule is presented in



Figure 24. This schedule accounts for the duration of pre-construction, construction, and close-out phases of the project. The project is expected to start in March and should end at the beginning of September, before the academic year starts. The total project will take approximately 132 days.

The crew for this project consists of 5 electricians, 2 civil laborers, 1 HVAC mechanic, 1 plumber, and 2 building maintenance staff. A workday is 8 hours for all workers except building maintenance staff. They may choose when they will work based on their schedule, however, for the proposed schedule, a 10-hour work week has been assumed for them. Since the daycare rooms are located primarily in the basement, close to the fan room, boiler room, and heater room, all HVAC retrofitting tasks will be conducted during the weekends to alleviate safety risks and noise impacts. Hence, a workweek of 16 hours has been considered for HVAC mechanics, plumbers, and electricians involved in those tasks. Window replacements and light shelf installation in the childcare rooms will take place during the weekends as well.

LED replacement and hanging Thermaliner curtains can be performed before and after the daycare operational hours. As for the other classrooms, window retrofits and LED replacements can take place during the weekdays of the summer months when there are no students. The majority of the solar panel installation tasks have been scheduled during weekdays because the tasks take place on the roof and will not interfere with the school activities. Delivery and hoisting of the solar panels, however, must occur during the weekend because of the huge quantity of solar panels that will be temporarily placed on the playground or parking lot. A mobile crane will be used to hoist the panels up on the roof where they will be stored. A power shutdown will be required for the solar panel installation, which will affect the day care activities. The date and time for the power shutdown will be coordinated with the school staff.

5.3 Safety

Since there will be ongoing activities in OSPS during the implementation of retrofits, the safety of the occupants must be a priority when considering how to carry out construction tasks. First, building occupants should be aware of the ongoing construction. Directional signage needs to be in place around construction work to prevent interference by mistake. In addition, noise and dust need to be kept at acceptable levels using noise and dust control techniques such as mufflers and wet cleaning methods. A list of building representative contacts for the building should also be in place for both contractors and occupants. In addition, contractors are responsible for keeping the work area clean to avoid occupant discomfort caused by the accumulation of dust, dirt, trash, and debris.

On the following Pages:

Figure 23 Cost Estimate for OSPS Energy Retrofit Project

Figure 24 Proposed Schedule for OSPS Energy Retrofit Project

OSPS RETROFIT PROJECT COST ESTIMATE

Direct Costs

Material Cost						Labour cost						Subtotal of Direct cost of item
Item #	Item description	Qty.	Unit	Unit Price (\$/unit)	Total Cost of Materials (\$)	Type of worker	# of workers	Unit Prod. Time (hrs/unit)	Total time (Hrs)	Hourly Wage (\$/hr)	Total cost of labour (\$)	
Lighting												
1	LED Replacement	1085	each	\$10	\$10,850	Building maintenance staff	1	0.1	108.5	N/A	N/A	\$10,850
2	Light Shelves	93	each	\$100	\$9,300	Civil Labourer	1	0.5	46.5	\$35	\$1,628	\$10,928
3	Dimmer Switches	91	each	\$24	\$2,184	Electrical worker	1	0.5	45.5	\$45	\$2,048	\$4,232
					Lighting Subtotal						\$3,675	\$26,010
Building Energy Performance (BEP)												
4	Vinyl Windows replacement	40	each	\$495	\$19,800	Civil Labourer	2	1.5	60	\$35	\$4,200	\$24,000
5	AC/Fan Units replacement	5	each	\$6,750	\$33,750	HVAC mechanic	1	8	40	\$100	\$4,000	\$37,750
6	Electric Boiler	1	each	\$57,850	\$57,850	Electrical worker	1	48	48	\$90	\$4,320	\$62,170
7	Thermaline Curtains	74	each	\$40	\$2,960	Building maintenance staff	1	0.15	11.1	N/A	N/A	\$2,960
8	Electric Water Heater	5	each	\$845	\$4,225	Plumber	1	3	15	\$92	\$1,380	\$5,605
					BEP Subtotal						\$146,385	\$132,485
Solar												
9	Solar Panel	317	each	\$283	\$89,711	Electrical worker	1	0.3	95.1	\$45	\$4,280	\$93,991
10	Inverter	14	each	\$2,375	\$33,244	Electrical worker	1	3	42	\$45	\$1,890	\$35,134
11	Panel Mounting system	317	each	\$32	\$10,144	Electrical worker	1	0.3	95.1	\$45	\$4,280	\$14,424
12	Combiner Box	3	each	\$246	\$737	Electrical worker	1	0.5	1.5	\$45	\$68	\$805
13	Crane rental	8	hours	\$260	\$2,080	Crane operator	1	1	8	\$60	\$480	\$2,560
					Solar Subtotal						\$10,995	\$146,915
Total Direct Cost											\$305,405	

Indirect Costs

Total Direct Cost			\$305,405
Item #	Item description	Percentage of Direct Costs	Subtotal
1	Overhead and Profit	10%	\$30,541
2	Contingency	10%	\$30,541
3	Insurance and liability	3%	\$9,162
4	Design fee	4%	\$12,216
5	Municipal Inspection	N/A	\$60.88
6	Material delivery and handling	2%	\$6,108
7	Labour Escalation	4%	\$12,216
8	HST	13%	\$39,703
Total Indirect cost			\$140,547.18
Total Construction Cost			\$445,950

Maintenance Costs

Total Direct Cost			
Item #	Item description	Cost/Unit	Subtotal
1	Solar Panel Cleaning	6.5	2060.5
2	Solar Panel Inspection	4500	900
Total Maintenance cost			\$2,960.50
Annual Maintenance Cost			\$2,960

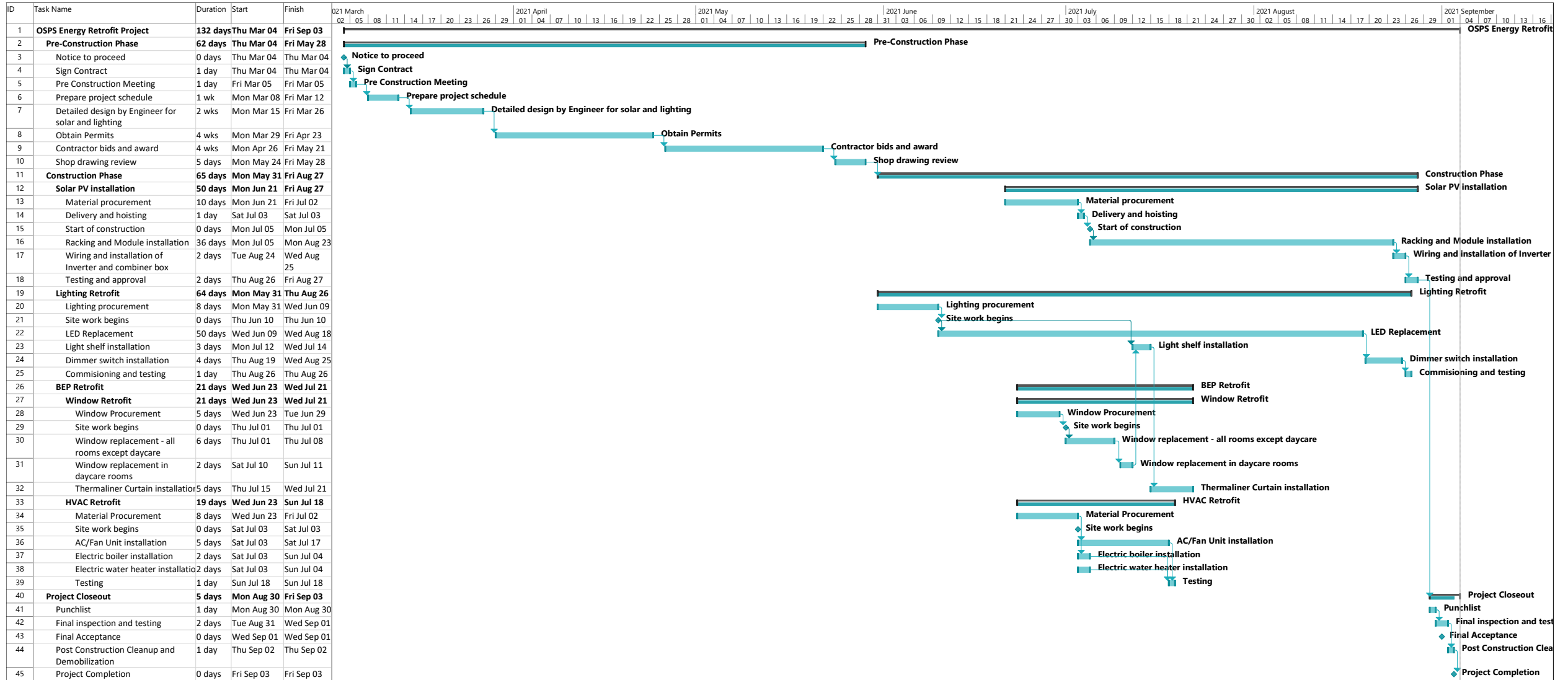

Project: Construction Schedule
Date: Fri May 29

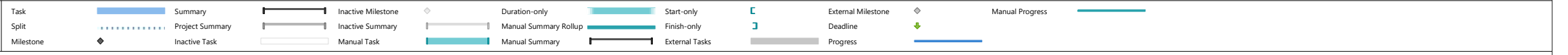



5.4 Cash Flow Plan

Orde Street Public School is a public school so external financing/sponsorship is important to the viability of the project. A combination of incentives, rebates and loans have been considered as avenues for project funding; regular operations are covered in the school's budget. Energy Star's Cash Flow Opportunity Calculator is used to determine the payback period, assess financing options, and determine the net present value of the retrofit project.

5.4.1 Incentives and Rebates

The OSPS energy retrofit project is eligible for numerous incentives provided by Save On Energy and Ontario's energy distribution company, Union Gas (Enbridge) [76][77]. A total of \$166,582.22 CAD is available within the first year of the project's completion, summarized below in Table 7.

Table 7 Incentives available to the TDSB to finance the proposal

Incentive Name	Amount	Total Amount Eligible (CAD)
Save On Energy Retrofit Program	\$0.05/kWh lighting saved \$0.1/kWh other measures	\$108,545.02
Union Gas RunSmart Building Optimization Incentive	\$0.3/m ³	\$32,295.40
Union Gas Equipment & Process Optimization	\$0.2/m ³	\$25,741.80
TOTAL		\$166,582.22

In addition to this, NLS recommends that OSPS collaborates with the TDSB to re-establish the SSLP Solar Panel Project recently completed in 2018 [78]. This program would cover 100% of solar panel material and installation costs, using the revenue generated from this project to fund further roof replacements for TDSB schools.

5.4.2 Loans

The Toronto District School Board's annual financial reports are made available to the public and were accessed to aid in financial planning for this project [79]. All \$83,103 CAD of the budget is allocated for and will not be available to fund the energy retrofit project [79][80]. NLS has selected the City of Toronto's Energy Retrofit Loan to finance all parts of the project not covered by incentives or the renewed solar program [81]. This amounts to \$132,453 CAD of the total cost. Annual savings from building energy and lighting improvements should be used to pay back the loan.

5.4.3 Financial Analysis

The cash flow analysis was performed using a total project cost of \$442,217 CAD and potential annual energy savings of \$126,842 CAD. These potential savings do not include solar savings. The assumption is made that, if the SSLP Project is rebooted those savings will go to the afore mentioned TDSB roof replacements.



Parameters included are:

- Incentives amounting to \$166,582 CAD total.
- Interest rate of 2.45% for all loan coverage (Canada’s current prime rate, as of March 2020) [82].
- 2.4% increase in project cost due to labor and material escalation from Statistics Canada [83].
- Annual projected increase in energy cost by 8% [84]

Two options are compared for their cash flow potential in Figure 25. Option A (Fast Track Financing) represents financing the project immediately, while Option B represents delaying by a year to potentially accrue project funding in the school budget. The net present value of Option A and B are +\$114,511 CAD and -\$307,194 CAD, respectively. Option B decreases interest payments but loses potential savings in the waiting period. Option A generates \$421,705.31 CAD more cash, this makes it the better financing decision. The total project breakeven point is estimated to occur at 4 years, 2 months with option A.

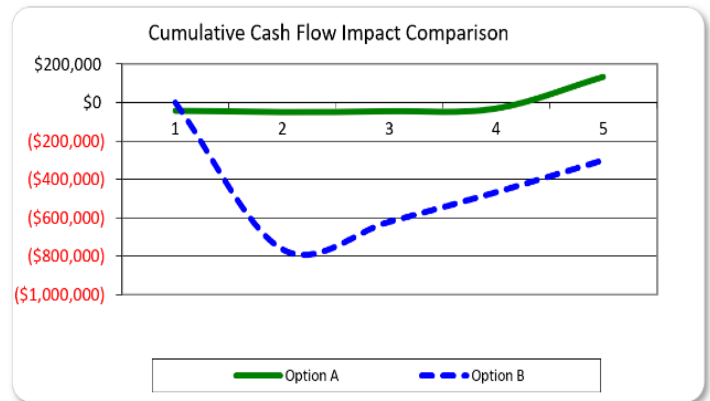

Figure 25 Cost of Delay and Cash Flow Analysis

6 Outreach

This section describes NLS’s energy awareness campaign at OSPS, which the team adjusted to account for the COVID-19 pandemic. Additionally, it discusses NLS’s other efforts to raise awareness of the Green Energy Challenge project, including blog posts, recruitment activities, and case competitions.

6.1 Energy Awareness Campaign and Volunteering at OSPS

Due to COVID-19, NLS transitioned its initial campaign and volunteering plan to online education through lessons accompanied by videos, handouts, interactive activities, blog posts, resources for further readings, and a game. The goal was to raise awareness of energy sources and basic building knowledge related to sustainability and environmental stewardship. The team prepared lessons for elementary and intermediate level students with the following themes: energy, building materials, and the relation between indoor space and human wellbeing. Each lesson involved careful planning and considerable work; with each member taking on responsibility for brainstorming content, making PowerPoint slides, narrating, and editing. The volunteering log with the work breakdown can be found in Appendix D – Volunteering Log.

6.1.1 Description of Lessons

NLS understands the importance of continuing education despite physical distancing guidelines. The video lessons encouraged close engagement with green building education. The team made each video interesting by using a wide range of visuals and animations. The videos for each lesson theme can be found on the CECA website, under [GEC Community Engagement](#), as shown in Figure 26.

For the first theme of energy, the elementary level lesson defined the concept of energy with everyday examples and identified renewable versus nonrenewable sources. The students were then guided through simple activities to test their knowledge, including a word search, energy appliances coloring sheet, and an energy Pictionary game. For the intermediate level, the lesson explained the relation between energy and electricity with an animation to discuss the principle behind each energy source as well as their advantages and disadvantages. Their activity was an energy audit, in



which students were to calculate the usage of household appliances to find out which sources consume the most electricity when plugged in at night. At the end of both lessons, students were given practical steps to expand their learning and do their part to save energy.

The second theme of building materials highlighted the importance of life cycle assessment and ways to evaluate the environmental impacts and cost of materials. For the elementary level, students were introduced to how wood, brick, glass, and steel for different components of a house are manufactured. In addition to a Pictionary game, the students applied their new knowledge through a craft activity and a word puzzle relating to different types of buildings.

Meanwhile, the intermediate level looked at material selection based on aesthetics, structure, thermal/moisture control, and air barriers. These students were asked to conduct two life cycle assessments for paper and a self-chosen object through a traditional production/consumption circle to draw recommendations on waste produced and describe necessary steps to convert to a zero-waste cycle.

The final set of lessons were inspired by the COVID-19 situation, focusing on how the indoor environment impacts physical and mental health. For both lessons, the team emphasized the interconnectedness of building design on human wellbeing regarding air quality, thermal comfort, and workspace. In particular, the intermediate level introduced and compared the WELL and LEED rating system. Both lessons ended with tips for students to maintain a healthy mind and body in indoor environments. For example, the elementary students were given a mindful bingo activity to try during quarantine to practice self-care and stay connected socially with family members, friends, and the local community. The intermediate students were encouraged to better understand and address their various states of mind throughout the day. For instance, under the “not motivated” state, there are some tips for making goals that are positive, visualized, exciting, and measurable and reduce procrastination.

Since this was a remote form of volunteering, it was difficult for NLS to obtain an exact number of students who engaged with the lessons. OSPS was able to provide the lesson material to three different teachers. Assuming each teacher has a class of 25, NLS estimates that about 75 students ranging from kindergarten to grade 8 received and learned from the material. The teachers provided NLS with feedback, such as making minor changes to the material format for the next set of lessons, which allowed the team to make the material easier to understand and improve the learning experience for the students.

6.1.2 Blog Posts

To showcase this Green Energy Challenge project to a larger audience, NLS continued to update their blog at <http://cecauoft.com/blog/>. These blog posts focused on the energy awareness lesson themes described above, with some posts on what each sub-team was accomplishing for this project. This allowed the team to extend their lesson plans with additional educational resources and to provide insight for audiences of all levels who want to learn more about sustainable building topics. For instance, the Wellness blog post extended the indoor space in lesson context to aesthetics in interior design. It also included new aspects, such as providing short videos to explain daylighting effects and air pollution issues in Canada.

Community Engagement 2020

To work with Orde Street Public School, we developed six lesson plans. We covered three different topics, for both elementary and middle school students. We also published several blog posts about these same topics, which can be found on the [Blog](#).

Topic 1 – Building Energy

Elementary



Middle School



Figure 26 Online Lesson Videos



6.1.3 Web Game – “Power Dilemma”

NLS has prototyped a game for students, as illustrated in Figure 27, to further boost their interest. Created in Javascript using the Phaser game engine, and named “Power Dilemma”, the game highlights the importance of saving power and building green. The user plays as the assistant to the monarch of a small country. The task is to construct the monarch’s castle according to their needs, while balancing energy use and budget. While playing interior designer for the monarch, the user must also decide the energy mix for the country. They must be careful, as too much pollution could lead to an uprising! The game challenges users to consider the effects of pollution and the importance of sustainability. It is currently playable at <http://cecauoft.com/power-dilemma>.



Figure 27 Prototpe of “Power Dilemma”

6.1.4 Letter from OSPS

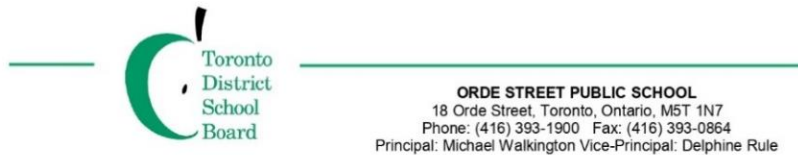

Friday, May 29, 2020

To Whom It May Concern,

A Team of Engineering Students (Pavani Perara, Noah Cassidy, Nicole and Serita), members of the Canadian Electrical Contractors, University of Toronto Student Chapter (CECA) have been in contact with Orde Street School, Toronto District School Board since the beginning of 2020.

They have worked to make a difference at Orde Street School by first coordinating an Energy Audit over a number of days at Orde Street School in February.

As of late the students have organized three lesson plans for primary and junior students. Their electronic lessons included topics of wellness, mini-life cycle assessment, and being green. The lessons were shared with teachers and teachers distributed them to their students. The members of the Canadian Electrical Contractors, University of Toronto Student Chapter (CECA) received feedback and adapted lessons to reflect the feedback given. Teachers enjoyed their interaction with the lead Noah Cassidy during April and May time period.

The U of T students were persistent, dedicated in their community engagement and were open to suggestions.

It has been a pleasure having their input into the school through their energy audit and the sharing their three lesson plans encouraging elementary student learning.

Michael

Michael Walkington
Orde Street School Principal



6.2 Other Efforts to Increase Awareness of the Green Energy Challenge

6.2.1 Gemini House Tour

NLS hosted its third annual tour of the Gemini House in October 2019 to provide an opportunity for the student community to learn about real-world applications of sustainable building retrofits. The Gemini House is a collaborative project between the University of Toronto and Ryerson University. It is a Victorian house in Toronto that was first constructed in the 1870's and began its transition into a low-energy, high-performance residence in 2013. Two tours, led by Professor Kim Pressnail of the University's Department of Civil & Mineral Engineering, provided students with insight into practical strategies used to cut down building energy usage. The tours engaged 10 students and allowed NLS to promote their student competitions and initiatives at the University.

6.2.2 Green Energy Challenge Workshops

NLS hosted a series of workshops for the four technical sub-teams of the Green Energy Challenge in the fall semester of 2019 to improve recruiting efforts and the student experience in the competition. The series began with the building energy performance workshop on building envelope designs that reduce energy usage in a facility. After learning some concepts of wall features, students were challenged to improve wall sections or create their own to suit conditions while optimizing materials. The series continued with the solar workshop, in which NLS collaborated with the University of Toronto Sustainability Office to organize a tour of the solar panel system at the University's Exam Centre. The students were excited to learn about how a solar panel system functions and how this system allows the facility to significantly offset daily electricity use. Next, the project management workshop challenged students to create a Gantt chart project schedule with a financing plan for a fictional energy retrofits project. Finally, the series ended with the lighting workshop, in which students did a short lighting audit in the University's Goldcorp Mining Innovation Suite to illustrate lighting intensity in this studio space.

Through these workshops, NLS spread awareness of the Green Energy Challenge within different engineering disciplines as well as mathematics and architecture. This resulted in an effective recruitment process, in which members chose how they would like to contribute to the Green Energy Challenge in a manner that aligned with their passions and skills to keep them motivated. Also, each workshop provided new students with fundamental knowledge that ended up being quite useful as they prepared the competition proposal in their sub-teams.

6.3 Local NECA/CECA Chapter Interactions

NLS hosted the third annual Sustainable Building Design Case Competition in January 2020 to further increase our presence at the University of Toronto. NLS provided a competition package with information on energy use, lighting, plug loads, and HVAC from one of the community service facilities we worked with for a past GEC. With this, NLS challenged student teams to prepare and present a short proposal to a panel of industry judges with innovative strategies that would help the facility reduce 60% of its energy usage while spreading awareness of energy efficient buildings.

The case competition itself included participation from two student teams as well as five judges, as shown in Figure 28.



Figure 28 Participants and Judges of the Third Annual Sustainable Building Design Case Competition



Northern Lights Solutions

CECA/NECA University of Toronto Student Chapter

Judges included University of Toronto Professor Brenda McCabe (faculty advisor); University of Toronto Professor Ian Sinclair; Greg Peniuk (IESO, also CECA U of T alumni); and Gregg Whitty (CECA).

The competition was a great success and provided students with an opportunity to explore their passions in sustainable building design and familiarize themselves with local industry leaders. The competition was featured in the Daily Commercial News (DCN) by Construct Connect, based on Eastern Canada’s construction industry. The full article can be found at: <https://canada.constructconnect.com/app/uploads/2019/03/2020-03-mechanical-electrical-contracting.pdf>.

6.4 Letter from Campus and Local Media Engagement

NLS collaborated with the University of Toronto’s Civil and Mineral Engineering Department to publish a June newsletter item showcasing the Green Energy Challenge project this year. The full article can be found at <https://civmin.utoronto.ca/amid-a-pandemic-u-of-t-engineering-design-team-pushes-ahead-on-energy-retrofit-project/>.

Posted June 1st, 2020 by Keenan Dixon

Amid a pandemic, U of T Engineering Design Team pushes ahead on energy retrofit project



Northern Lights Solutions team at their energy audit at Orde Street Public School.

One lesson this pandemic brought to light is that a reduced carbon footprint can have a measurable impact on the environment. Students from the Department of Civil & Mineral Engineering knew that to be the case when they began work on an energy retrofit project for a local school.

Northern Lights Solutions (NLS) is a student design team in the [Canadian/National Electrical Contractors Association University of Toronto Student Chapter](#) (CECA/NECA U of T). Each year, the team takes part in the [ELECTRI International Green Energy Challenge](#) (GEC). They partner up with a local community service organization, to propose retrofits and implement an energy awareness campaign that helps the facility to reduce its overall energy consumption.

"This competition is a great chance for us students to learn about sustainable building designs and give back to our local community," said Noah Cassidy (CivE Year 4), President of CECA/NECA U of T. "I love building on our past success with enthusiastic students and initiatives to enhance the competition experience."

Before the 2020 GEC began, the CECA/NECA U of T Executive Team improved their recruiting efforts with a series of workshops focused on each sub team in the competition. These workshops ranged from interactive activities to tours of a real solar panel system on campus (pictured on the right).

"The executive team took a different approach to marketing our club early on this school year," said Pavani Perera (CivE Year 4), Student Outreach Coordinator of CECA/NECA U of T. "These workshops let us engage with new students by giving them the chance to find out which sub-teams align with their interests and skills. From there, we ended up with a diverse, committed team to tackle GEC".

With new recruiting initiatives, NLS continues to grow with students from various STEM programs passionate about green energy, community involvement, and leadership development. The 2020 GEC team leads include: Rose Zhang (CivE Year 2) (Co-Project Manager); Adrian Sin (CivE Year 3) (Co-Project Manager); Mahia Anhara (CivE Year 3) (Project Management); Bo Zhao (CivE Year 1) (Building Energy Performance); Ziyi Wang (CivE Year 2) (Lighting); Keziah Nongo (CivE Year 2) (Solar), and Kin Hey Chan (CivE Year 1) (Community Engagement).

This year, NLS is working with Orde Street Junior Public School, located right by the U of T campus in downtown Toronto. In February, the team conducted an energy audit at the school to figure out energy usage with electricity, building enclosures, mechanical systems, and lighting.

Since then, each sub team was hard at work developing retrofits that could realistically be implemented to improve the facility's energy performance as well as generate energy on-site. The main goal is to find cost-effective ways to achieve net-zero energy, in which the facility generates as much or more energy as it uses. Some retrofits the team focused on include efficient boilers, light shelves, and a roof-mounted solar photovoltaic system connected to the grid.

The unique challenge this year was the outreach portion of the project. Due to COVID-19 restrictions, the team could not carry out their energy awareness campaign in person at the school; instead, they took a more creative approach with virtual learning. NLS created a series of remote lesson plans for both elementary and intermediate level students at the school.

"Our team has put together lesson plans, videos, blog posts, and an online game with the themes of energy, building materials, and how the indoor environment impacts human wellbeing," said Chan. "It's been fun for us to create and we hope the students learn to do their part for the environment right from home. We really appreciate the support from the school staff and parents in delivering this material".

NLS wrapped up their proposal for the June 1st GEC deadline. They are determined to top their second place finish last year for their [work at Armour Heights Presbyterian Church](#) in North York. Back in September 2019, they got the exciting opportunity to present that project and be recognized at the NECA Convention in Las Vegas. This year, if selected as a top team, NLS will get to present their proposal in Chicago!

"We'd like to thank Professor Brenda McCabe (our faculty advisor), the Department of Civil & Mineral Engineering, and our industry connections at CECA for the amazing support and resources they provide us with each year. We plan to continue working hard to help our local communities!" said Cassidy.

Posted in [News](#) | Tags: [student experience](#), [student life](#), [sustainability](#), [Undergraduate](#)



7 References

- [1] "Orde Street Public School", *Tdsb.on.ca*, 2020. [Online]. Available: <https://www.tdsb.on.ca/Find-your/Details/schno/5258?displayModule=Details%20of%20a%20School>. [Accessed: 13- May- 2020].
- [2] TDSB, *Orde Street Public School*. Toronto: TDSB, 2020.
- [3] Technical Services Division Design & Construction Unit, *Orde Street Public School 1st Floor*. Toronto: Tdsb, 2019.
- [4] Toronto District School Board, "Energy consumption and Greenhouse Gas Emissions Reporting – for 2013," 2014. [Online]. Available: www.tdsb.on.ca/Portals/0/AboutUs/docs/GEA_2013-2014.pdf. [Accessed April 2020].
- [5] Greater Cincinnati Energy Alliance, "Lightbulb Efficiency Comparison Chart," 2019. [Online]. Available: greatercea.org/lightbulb-efficiency-comparison-chart/. [Accessed April 2020].
- [6] Cleaver-Brooks, "CLEAVER-BROOKS Model 5 Boiler Size 8000 Low Water Volume," 2004. [Online]. Available: cleaverbrooks.com/products-and-solutions/boilers/flexiblewt/model-5/Model%205%20Operating%20and%20Maintenance%20Manual%20-%20Low%20Water%20Volume.pdf. [Accessed: April 2020]. [Accessed: April 2020].
- [7] Energy Star, "Energy Star Portfolio Manager®." [Online]. Available: portfoliomanager.energystar.gov/pm/login.html;jsessionid=A66F8866482092CCC35335D482D79B79#energy. [Accessed April 2020]. [Accessed April 2020].
- [8] Office of Energy Efficiency & Renewable Energy, "Asset Score." [Online]. Available: buildingenergyscore.energy.gov/. [Accessed April 2020]. [Accessed April 2020].
- [9] Amazon, "Eclipse Thermaliner Blackout Panel Pair, 54x80, White." [Online]. Available: www.amazon.com/ECLIPSE-Blackout-Curtains-Bedroom-Thermaliner/dp/B002LE88FM?th=1. [Accessed April 2020].
- [10] Networx, "Will Blackout Curtains Keep You Cooler This Summer?," 2020. [Online]. Available: www.networx.com/article/will-blackout-curtains-keep-you-cooler-t. [Accessed April 2020].
- [11] The American Society of Heating, Refrigerating and Air-Conditioning Engineers, "Chapter 15: Fenestration," 2015. [Online]. [Accessed April 2020].
- [12] P. Sabaliuk, "Review of Gas-Filled Window Technology: Summary Report." [Online]. Available: web.ornl.gov/sci/buildings/conf-archive/1982%20B2%20papers/036.pdf. [Accessed April 2020].
- [13] Remodeling Expense, "Cost of Double Pane Window," 2020. [Online]. Available: www.remodelingexpense.com/costs/cost-of-double-pane-window/#rt-tabbed-443. [Accessed April 2020].
- [14] Cleaver-Brooks, "Boiler Efficiency Guide," 2010. [Online]. Available: cleaverbrooks.com/reference-center/insights/Boiler%20Efficiency%20Guide.pdf. [Accessed April 2020].
- [15] Cleaver-Brooks, "Electric Resistance! Boiler Steam or Hot Water Efficiency Guide," 2019. [Online]. Available: cleaverbrooks.com/docs/boiler-books/CB-Electric-Boilers-BB.pdf. [Accessed April 2020].



- [16] Home Depot, “Rheem Performance Platinum 50 Gal Gas Water Heater with 12 Year Warranty.” [Online]. Available: www.homedepot.ca/product/rheem-performance-platinum-50-gal-gas-water-heater-with-12-year-warranty/1000792353?eid=PS_GOOGLE_D26%20-%20Vendor-Funded%20%7C%20Rheem%20%7C%20Shopping_Rheem_PRODUCT_GROUP_pla-294682000766&gclid=Cj0KCQjwka_1BRCPARIsAMIUmErK85dP4EkBj8wDXkyoIkpZh0l4rFT81JnE90bgHslE2nnSlQgpyeEaAh9eEALw_wcB&gclsrc=aw.ds. [Accessed April 2020].
- [17] AO Smith Water Heating Sizing, “School Requirements,” 2010. [Online]. Available: www.hotwatersizing.com/ApplicationData/School.aspx. [Accessed April 2020].
- [18] U.S Department of Energy, “Central Air Conditioning Energy Saver.” [Online]. Available: www.energy.gov/energysaver/central-air-conditioning. [Accessed April 2020].
- [19] Budget Heating & Air Conditioning Inc, “12.5 Ton Daikin Two Speed Central Air Package Unit 3 Phase, DCC150XXX,” 2020. [Online]. Available: www.budgetheating.com/12-5-Ton-Daikin-Central-Air-Package-Unit-208-230V-p/172057.html. [Accessed April 2020].
- [20] Energy Star, “Properly Sized Room Air Conditioners.” [Online]. Available: www.energystar.gov/index.cfm?c=roomac.pr_properly_sized. [Accessed April 2020].
- [21] Energy Vanguard, “Why is Air Condition Capacity Measured in Tons?,” 2012. [Online]. Available: www.energyvanguard.com/blog/55629/Why-Is-Air-Conditioner-Capacity-Measured-in-Tons. [Accessed April 2020].
- [22] Modernize: Home Empowerment, “How Much Does an Electrical Boiler Cost to Install,” 2020. [Online]. Available: modernize.com/hvac/heating-repair-installation/boiler/electric. [Accessed April 2020].
- [23] Ontario Energy Board, “Natural Gas Rates,” 2012. [Online]. Available: www.oeb.ca/rates-and-your-bill/natural-gas-rates. [Accessed April 2020].
- [24] Energy Hub, “Electricity Prices in Canada 2020,” 2020. [Online]. Available: www.energyhub.org/electricity-prices/. [Accessed April 2020].
- [25] LAS Shutters + Windows, “How Much Energy Are You Losing Through Your Old Windows?,” 2016. [Online]. Available: lashome.com/how-much-energy-are-you-losing-through-your-old-windows/. [Accessed April 2020].
- [26] Wayfair, “Light Filtering Insulated Solid Color Semi-Sheer Thermal Liner,” 2020. [Online]. Available: www.wayfair.ca/Winston-Porter--Light-Filtering-Insulated-Solid-Color-SemiSheer-Thermal-Liner-CM12496015-L6260-K--C002072502.html?refid=GX432526579658-C002072502&device=c&ptid=900165089679&targetid=pla-900165089679&network=g&ireid=4802326&gclid=CjwKCAjwqJ_1BRBZEiwAv73uwPFZJMpumyKgSF17ovcnSRvlc8dL4zRHERntvfuxkWSO4FkuUAGwQhoCD9UQAvD_BwE. [Accessed April 2020].
- [27] Angies List, “How Much Does Window Replacement Cost?,” 2020. [Online]. Available: www.angieslist.com/articles/how-much-does-window-replacement-cost.html. [Accessed April 2020].
- [28] Deconovo: Your Home Decor Specialists, “Seriously, Do Thermal Curtains Really Work?,” 2019. [Online]. Available: deconovo.com/blog/seriously-do-thermal-curtains-really-work/. [Accessed April 2020].



- [29] Natural Resources Canada, "Major Energy Retrofit Guidelines for Commercial and Institutional Buildings (K–12 SCHOOLS)," 2017. [Online]. Available: <https://www.nrcan.gc.ca/sites/www.nrcan.gc.ca/files/oee/buildings/pdf/RetrofitGuidelines-e.pdf>. [Accessed: 18-Mar-2020]
- [30] Government of Canada, "Lighting Ergonomics - Survey and Solutions : OSH Answers", Ccohs.ca. [Online]. Available: https://www.ccohs.ca/oshanswers/ergonomics/lighting_survey.html. [Accessed: 31- May-2020]. Government of Canada, "Lighting Ergonomics - Survey and Solutions : OSH Answers", Ccohs.ca. [Online]. Available: https://www.ccohs.ca/oshanswers/ergonomics/lighting_survey.html. [Accessed: 31- May-2020].
- [31] C. Meyer, "Lightbulb Efficiency Comparison Chart and Analysis," The Greater Cincinnati Energy Alliance, 20-Aug-2015. [Online]. Available: <https://greatercea.org/lightbulb-efficiency-comparison-chart/>. [Accessed: 18-Mar-2020].
- [32] Home Depot, "48 in.16-Watt Cool White T8 or T12 Dimmable Linear LED Tube Light Bulb (2-Pack)," [Online]. Available: <https://www.homedepot.com/p/toggled-48-in-16-Watt-Cool-White-T8-or-T12-Dimmable-Linear-LED-Tube-Light-Bulb-2-Pack-D416-40321-2/308086232>. [Accessed: 30 May 2020].
- [33] Home Depot, "75-Watt Equivalent BR20 Dimmable Energy Star LED Light Bulb Soft White (3-Pack)," [Online]. Available: <https://www.homedepot.com/p/EcoSmart-75-Watt-Equivalent-BR20-Dimmable-Energy-Star-LED-Light-Bulb-Soft-White-3-Pack-1003020502/303667905>. [Accessed: 30 May 2020].
- [34] "TechNote 02 Daylight Light Shelf", Wbdg.org, 2020. [Online]. Available: <https://www.wbdg.org/FFC/ARMYCOE/TECHNOTE/technote02.pdf>. [Accessed: 18 Mar. 2020].
- [35] Design Buildings "Light shelf", Designingbuildings.co.uk, 2020, February 2020. [Online]. Available: https://www.designingbuildings.co.uk/wiki/Light_shelf. [Accessed: 18 Mar. 2020].
- [36] Windows and Envelope Materials Group, "Daylighting Systems." [Online]. Available: <https://facades.lbl.gov/sites/default/files/Downloads/daylighting-c4.pdf>. [Accessed: 18 May 2020].
- [37] Kawneer Company, Inc, "InLighten™ (Light Shelf)," January 2017. [Online]. Available: https://www.kawneer.com/kawneer/north_america/catalog/97911/ADMG050EN.pdf. [Accessed: 18 May 2020].
- [38] H. Kolloosche, "Are Dimmers Worth Their Costs?", discountlighting, 2016. [Online]. Available: <https://www.discountlighting.com.au/blog/lighting-tips-and-tricks/are-dimmers-worth-their-costs/>. [Accessed: 18 Mar. 2020].
- [39] Home Depot, "Skylark Contour LED+ Dimmer Switch for Dimmable LED, Halogen and Incandescent Bulbs, Single-Pole or 3-Way, White", homedepot. [Online]. Available: <https://www.homedepot.com/p/Lutron-Skylark-Contour-LED-Dimmer-Switch-for-Dimmable-LED-Halogen-and-Incandescent-Bulbs-Single-Pole-or-3-Way-White-CTCL-153PDH-WH/202517700>. [Accessed: 17 Apr. 2020].
- [40] M. A. Contín, M. M. Benedetto, M. L. Quinteros-Quintana, and M. E. Guido, "Light pollution: the possible consequences of excessive illumination on retina," Eye (London, England), Feb-2016. [Online]. Available: <https://www.ncbi.nlm.nih.gov/pmc/articles/PMC4763120/>. [Accessed: 18-May-2020].



- [41] Canadian Centre for Occupational Health, "The Young Workers Zone : Teaching Tools : Physical Hazards: Lighting," The Young Workers Zone : Teaching Tools : Physical Hazards: Lighting, 12-Jul-2010. [Online]. Available: https://www.ccohs.ca/teach_tools/phys_hazards/lighting.html. [Accessed: 18 May 2020].
- [42] J. Barnes, "How Dimmers Save Energy", Ideas & Advice | Lamps Plus, 2018. [Online]. Available: <https://www.lampsplus.com/ideas-and-advice/how-dimmers-save-energy/>. [Accessed: 22 Apr. 2020].
- [43] City of Toronto, "FAIR WAGE SCHEDULE 2016-2019 I.C.I Work", Current & Previous Fair Wage Schedules, 2017. [Online]. Available: <https://www.toronto.ca/wp-content/uploads/2017/08/8d6f-ICI-Work.pdf>. [Accessed: 30 May 2020].
- [44] "Electricity Prices in Canada (Updated 2020)", energyhub.org, 2020. [Online]. Available: <https://www.energyhub.org/electricity-prices/>. [Accessed: 30 Apr. 2020].
- [45] "Orde Street Junior Public School", Orde Street Junior Public School, 2020. [Online]. Available: <https://www.google.ca/maps/place/Orde+Street+Junior+Public+School/@43.6583217,-79.3942371,17z/data=!3m1!4b1!4m5!3m4!1s0x882b34c7dd0c0115:0x5ce5211f5fb5aaf9!8m2!3d43.6583217!4d-79.3920484>. [Accessed: 18- May- 2020].
- [46] "Net Metering - Toronto Hydro", Torontohydro.com, 2020. [Online]. Available: <https://www.torontohydro.com/grid-connections/net-metering>. [Accessed: 31- May- 2020].
- [47] "The Ontario Building Code | Roof Access", Buildingcode.online, 2020. [Online]. Available: <http://www.buildingcode.online/258.html>. [Accessed: 31- May- 2020].
- [48] "Roofs Suitable for Solar Photovoltaics (PV) - National Energy Foundation", Nef.org.uk, 2020. [Online]. Available: <http://www.nef.org.uk/knowledge-hub/solar-energy/roofs-suitable-for-solar-photovoltaics-pv>. [Accessed: 31- May- 2020].
- [49] "Monocrystalline vs. Polycrystalline Solar Panels | EnergySage", Energysage.com, 2020. [Online]. Available: <https://www.energysage.com/solar/101/monocrystalline-vs-polycrystalline-solar-panels/>. [Accessed: 31- May- 2020].
- [50] "Polycrystalline vs Monocrystalline solar panels: Which is the best type, and why?", Solar Reviews, 2020. [Online]. Available: <https://www.solarreviews.com/blog/pros-and-cons-of-monocrystalline-vs-polycrystalline-solar-panels#advantagesMonocrystalline>. [Accessed: 31- May- 2020].
- [51] "Canadian Solar HiDM CS1H-320MS 320W Solar Panel - Low Price", Solarelectricsupply.com, 2020. [Online]. Available: <https://www.solarelectricsupply.com/solar-panels/canadian-solar/canadian-solar-cs1h-320ms-hidm-mono-perc-solar-panel>. [Accessed: 31- May- 2020].
- [52] Canadiansolar.com, 2020. [Online]. Available: https://www.canadiansolar.com/wp-content/uploads/2019/12/Canadian_Solar-Datasheet-HiDM_CS1H-MS_EN.pdf. [Accessed: 31- May- 2020].
- [53] "Canadian Solar HiDM Black CS1H-320MS 320W Mono Solar Panel", Solaris, 2020. [Online]. Available: <https://www.solaris-shop.com/canadian-solar-hidm-black-cs1h-320ms-320w-mono-solar-panel>. [Accessed: 31- May- 2020].



- [54] "What are the different types of solar mounting systems? | KB Racking", Kbracking.com, 2020. [Online]. Available: <https://www.kbracking.com/solar-panel-mounting-systems>. [Accessed: 31- May- 2020].
- [55] "PR2 - Ballasted Flat Roof System - One Tool to Install", Polar Racking, 2020. [Online]. Available: <https://www.polarracking.com/products/pr2/#video>. [Accessed: 31- May- 2020].
- [56] "Polar Racking Inc. Selected For Toronto District School Board PV Projects - Polar Racking", Polar Racking, 2020. [Online]. Available: <https://www.polarracking.com/tdsb-polar/>. [Accessed: 31- May- 2020].
- [57] Amazon.com, 2020. [Online]. Available: https://www.amazon.com/ECO-WORTHY-String-Combiner-Circuit-Breakers/dp/B01N96GJFT?ref_=fsclp_pl_dp_1. [Accessed: 31- May- 2020].
- [58] 2020. [Online]. Available: <https://www.youtube.com/watch?v=H2aeV8d7SJY>. [Accessed: 31- May- 2020].
- [59] Usa.krannich-solar.com, 2020. [Online]. Available: https://usa.krannich-solar.com/fileadmin/content/data_sheets/inverter/usa/STPTL-US12-24EXP-DUS132533W.pdf. [Accessed: 31- May- 2020].
- [60] "Solar Cable Gauge Calculator", Renogy.com, 2020. [Online]. Available: https://www.renogy.com/calculators#tab_solar-cable. [Accessed: 31- May- 2020].
- [61] "Determining Module Inter-Row Spacing", CED Greentech, 2020. [Online]. Available: <https://www.cedgreentech.com/article/determining-module-inter-row-spacing>. [Accessed: 31- May- 2020].
- [62] J. Alfsen and J. Alfsen, "How to Calculate PV String Size — Mayfield Renewables", Mayfield Renewables, 2020. [Online]. Available: <https://www.mayfield.energy/blog/pv-string-size>. [Accessed: 31- May- 2020].
- [63] "Electricity Prices in Canada (Updated 2020)", energyhub.org, 2020. [Online]. Available: <https://www.energyhub.org/electricity-prices>. [Accessed: 31- May- 2020].
- [64] "What is positive cash flow? definition and meaning", BusinessDictionary.com, 2020. [Online]. Available: <http://www.businessdictionary.com/definition/positive-cash-flow.html>. [Accessed: 31- May- 2020].
- [65] M. Dilthey, "How to Maintain Your Solar Panels Year Round | Solar Power Authority", Solar Power Authority, 2020. [Online]. Available: <https://www.solarpowerauthority.com/maintain-solar-system-year-round>. [Accessed: 31- May- 2020].
- [66] "Roofs Suitable for Solar Photovoltaics (PV) - National Energy Foundation", Nef.org.uk, 2020. [Online]. Available: <http://www.nef.org.uk/knowledge-hub/solar-energy/roofs-suitable-for-solar-photovoltaics-pv>. [Accessed: 31- May- 2020].
- [67] "What initiatives are available? | Ontario Energy Board", Oeb.ca, 2020. [Online]. Available: <https://www.oeb.ca/industry/tools-resources-and-links/information-renewable-generators/what-initiatives-are-available>. [Accessed: 31- May- 2020].
- [68] "Ontario power stats – Canadian Energy Issues", Canadianenergyissues.com, 2020. [Online]. Available: <http://canadianenergyissues.com/ontario-power-stats/>. [Accessed: 31- May- 2020].
- [69] "Hydro One", Hydroone.com, 2020. [Online]. Available: <https://www.hydroone.com/business-services/generators/net-metering>. [Accessed: 31- May- 2020].



- [70] "What initiatives are available? | Ontario Energy Board", Oeb.ca, 2020. [Online]. Available: <https://www.oeb.ca/industry/tools-resources-and-links/information-renewable-generators/what-initiatives-are-available>. [Accessed: 31- May- 2020].
- [71] "Lifetime greenhouse emissions of solar PV systems", CNG Solar Engineering, 2020. [Online]. Available: <https://cngsolarengineering.com/lifetime-greenhouse-emissions-of-solar-pv-systems-vs-coal-powered-systems/>. [Accessed: 31- May- 2020].
- [72] "Canadian Household Emissions | Climate Action NOW!", Climateactionnow.ca, 2020. [Online]. Available: <https://climateactionnow.ca/canadian-household-emissions>. [Accessed: 31- May- 2020].
- [73] Government of Canada, "Job Bank", Job Bank. [Online]. Available: <https://www.jobbank.gc.ca/home>. [Accessed: May 2020].
- [74] "Get-A-Quote.net - Online Construction Costs for Contractors", Get-a-quote.net. [Online]. Available: <http://www.get-a-quote.net/QuoteEngine/costbook.asp?WCI=CostIntroFrameSet>. [Accessed: May 2020].
- [75] City of Toronto, "When Do I Need a Building Permit?", City of Toronto. [Online]. Available: <https://www.toronto.ca/services-payments/building-construction/apply-for-a-building-permit/when-do-i-need-a-building-permit/>. [Accessed: May 2020].
- [76] "About the Retrofit program | Save on Energy", *Saveonenergy.ca*, 2020. [Online]. Available: <https://saveonenergy.ca/For-Business-and-Industry/Programs-and-incentives/Retrofit-Program/About>. [Accessed: 01- Jun- 2020]
- [77] "Equipment & Process Optimization - Business - Union Gas", *Uniongas.com*, 2020. [Online]. Available: <https://www.uniongas.com/business/save-money-and-energy/engineering-projects/equipment-process-optimization>. [Accessed: 01- Jun- 2020]. (edited)
- [78] TDSB, "Solar Panel Projects," TDSB, [Online]. Available: <https://tdsb.on.ca/About-Us/Facility-Services/Solar-Schools-Project>. [Accessed: May 2020].
- [79] TDSB, "School Budgets - 2019 - 2020, Orde Street Public School," TDSB, [Online]. Available: <https://tdsb.on.ca/About-Us/Business-Services/Budgets-and-Financial-Statements/School-Budgets?SchoolNo=5258>. [Accessed: May 2020].
- [80] TDSB, "School-by-school budget information for the 2019-20 school year," TDSB, [Online]. Available: <https://tdsb.on.ca/Portals/0/aboutus/Business%20Services/School-by-school%20budget%20information%20for%20the%202019-20%20school%20year.pdf>. [Accessed: May 2020].
- [81] City of Toronto, "Energy Retrofit Loans," [Online]. Available: <https://www.toronto.ca/services-payments/water-environment/environmental-grants-incentives/energy-retrofit-loans/>. [Accessed: May 2020].
- [82] "Prime rate Canada," [Online]. Available: <https://www.ratespy.com/prime-rate-canada>. [Accessed: May 2020].
- [83] A. Carrick, "2010-2019 Trends in Canadian Building Product Material Costs," Daily Commercial News, Mar. 2020. [Online]. Available: <https://canada.constructconnect.com/dcn/news/economic/2019/03/2010-2019-trends-canadian-building-product-material-costs>. [Accessed: May 2020].



Northern Lights Solutions

CECA/NECA University of Toronto Student Chapter

- [84] T. Jackson, A. Stedman, et al., “Evaluating electricity Price Growth in Ontario,” Fraser Institute, 2017. [Online]. Available: <https://duckduckgo.com/l/?kh=1&uddg=https%3A%2F%2Fwww.fraserinstitute.org%2Fsites%2Fdefault%2Ffiles%2Fevaluating-electicity-price-growth-in-ontario.pdf>. [Accessed: May 2020].



ELECTRIC RESISTANCE BOILERS

Steam or Hot Water

Boiler Book
10/2019



Table 3. Model WB Ratings 380V, 415V Supplies

MODEL	Vessel Capacity (gallons)	Rated kW	MBTUHR	ELEMENTS Qty	MW	3-PHASE AMPERES			
						380V/415V	380V	415V	
WB-120	16	15	51	3	5	1	181.5	23	21
		36	105	6	5	1	183.5	48	42
		45	154	9	5	2	181.5, 183.0	68	63
		60	205	12	5	2	202.0	91	83
		75	256	15	5	3	181.5, 202.0	114	104
WB-121	16	75	256	15	5	3	181.5, 202.0	114	104
		90	307	18	5	3	183.0, 202.0	137	125
		105	358	21	5	3	183.0, 202.0	160	145
		120	409	24	5	4	403.0	182	167
		135	460	27	5	4	181.5, 403.0	205	188
WB-201	78	300	1024	60	5	10	603.0, 2000	458	417
		330	1126	66	5	5	593.0	228	209
		360	1228	72	5	5	181.5, 593.0	251	236
		390	1331	78	5	6	483.0, 489.0	301	459
		420	1433	84	5	6	503.0, 509.0	347	501
WB-202	78	450	1535	90	5	15	503.0, 509.0	503	544
		600	2047	120	5	14	293.0, 1629.0	638	684
		750	2559	150	5	23	183.0, 1189.0	944	1020
		900	3071	180	5	24	1200.0	1084	1052
		1050	3583	210	5	25	1189.0, 1629.0	1224	1195
WB-241	122	540	1842	84	10	18	503.0, 509.0	605	751
		630	2150	100	10	18	503.0, 509.0	668	792
		720	2457	120	10	19	183.0, 1629.0	729	835
		810	2765	140	10	21	303.0, 509.0	857	876
		900	3071	160	10	22	293.0, 1629.0	1003	918
WB-242	122	1050	3583	210	10	27	183.0, 3090	1212	1127
		1140	3890	230	10	28	640.0, 4890	1276	1169
		1230	4197	250	10	29	700.0, 5090	1322	1210
		1320	4504	270	10	30	503.0, 6090	1387	1262
		1410	4811	290	10	31	503.0, 7090	1453	1304

Table 3. Model WB Ratings 380V, 415V Supplies (Continued)

MODEL	Vessel Capacity (gallons)	Rated kW	MBTUHR	ELEMENTS Qty	MW	3-PHASE AMPERES			
						380V/415V	380V	415V	
WB-243	142	1500	4818	290	10	33	380.0, 1029.0	1551	1277
		1600	5125	310	10	34	280.0, 1029.0	1551	1419
		1700	5432	330	10	35	180.0, 1029.0	1617	1515
		1800	5739	350	10	36	573.0, 2020	1683	1611
		1900	6046	370	10	37	560.0, 5090	1847	1644
WB-302	315	1140	3890	230	10	36	480.0, 1029.0	1732	1686
		1230	4197	250	10	39	380.0, 1189.0	1778	1628
		1320	4504	270	10	40	280.0, 1289.0	1823	1669
		1410	4811	290	10	41	180.0, 1389.0	1869	1711
		1500	5118	310	10	42	1489.0	1914	1753
WB-303	370	1200	4299	225	10	43	580.0, 1189.0	1960	1795
		1300	4606	245	10	44	480.0, 1289.0	2006	1836
		1400	4913	265	10	45	380.0, 1389.0	2051	1878
		1500	5220	285	10	46	280.0, 1489.0	2097	1920
		1600	5527	305	10	47	180.0, 1589.0	2142	1962
WB-421	425	1470	5018	300	10	48	1689.0	2186	2003
		1500	5118	310	10	49	580.0, 1589.0	2233	2045
		1530	5220	320	10	50	480.0, 1489.0	2279	2087
		1560	5323	330	10	51	380.0, 1589.0	2325	2129
		1590	5425	340	10	52	280.0, 1689.0	2370	2170

DIMENSIONS AND RATINGS

BOILER BOOK ELECTRIC BOILERS

Table 2. Model WB Ratings 208V, 240V Supplies

MODEL	Vessel Capacity (gallons)	Rated kW	MBTUHR	ELEMENTS Qty	MW	NUMBER AND kW of CONTRACTORS			3-PHASE AMPERES		
						208V/240V	208V	240V	208V	240V	240V
WB-120	16	12	41	3	4	1	1	1	181.2	34	30
		18	61	3	6	1	1	1	181.8	51	44
		24	82	6	4	2	1	2	182.4	68	59
		30	102	6	5	2	1	2	183.0	84	73
		36	123	6	6	2	1	2	183.6	101	87
WB-121	16	45	154	9	5	3	1	3	183.0, 181.8	126	109
		54	184	9	6	3	1	3	183.0, 181.8	151	131
		60	205	12	5	4	1	4	203.0	167	145
		72	248	12	6	4	1	4	203.0	201	174
		90	307	15	6	5	1	5	203.0, 181.8	251	217
WB-122	25	108	368	18	6	6	1	6	303.0	301	261
		144	491	24	6	8	1	8	403.0	401	347
		180	614	30	6	10	1	10	503.0	501	391
		198	676	33	6	11	1	11	503.0, 181.8	551	477
		210	737	36	6	12	1	12	603.0	601	521
WB-201	78	234	798	39	6	13	1	13	603.0, 181.8	651	564
		252	860	42	6	14	1	14	703.0	701	607
		270	921	45	6	15	1	15	703.0, 181.8	751	651
		288	983	48	6	16	1	16	803.0	801	694
		324	1105	54	6	18	1	18	803.0	901	781
WB-202	78	360	1228	60	6	20	1	20	483.0, 489.0	1001	868
		396	1350	66	6	22	1	22	603.0, 181.8	1101	954
		432	1474	72	6	24	1	24	603.0	1201	1041



Rheem Performance Platinum 50 Gal Gas Water Heater with 12 Year Warranty

Model # 630151 | Store SKU # 1000792353
★★★★★ (202)

\$998.00 / each

Overview

Model # 630151 Store SKU # 1000792353

The Rheem Performance Line. Exclusive to the Home Depot! A 50 gallon gas water heater providing an ample supply of water to households with 3-5 people. This model has a 12 year limited tank and parts warranty plus a 1 year in home labour warranty. Featuring a Honeywell, electronic ignition (no pilot light), gas valve with self diagnostic capabilities that alerts the user to the operating status of the unit. A brass valve upgrade for superior leak protection. 40 000 BTU input for exceptional hot water delivery. Want better efficiency, limitless hot water, and space savings? Consider Rheem condensing tankless (SKU # 1000730128).

- 50 gal. tank provides ample hot water for households with 3-5 people.
- Honeywell, electronic ignition (no pilot light), self diagnostic gas valve. Alerts the user to the operating status of the heater.
- 12 year tank and parts, 1 year labour limited warranty.
- .67 efficiency rating
- 40 000 BTU input for fast water temperature recovery.
- WIFI compatible (control from your smart device), with purchase of WIFI module (SKU 1000819401)

Specifications

Dimensions

Assembled Depth (in inches)

23.75

Assembled Height (in inches)

55.5

Assembled Weight (in lbs)	140
Assembled Width (in inches)	23.75
Packaged Depth (in inches)	30.5
Packaged Height (in inches)	57.125
Packaged Weight (in lbs)	183
Packaged Width (in inches)	24.813

Details

Capacity (Gal / Imp.Gal)	50
Certified	Yes
Commercial/Residential	Residential
Country of Origin	MX-Mexico
Gas Type	Natural Gas
Parts Warranty (Years)	1



9 Appendix B – Product Data Sheets for Technical Analysis 2



toggled Model # D416-40321-2 ★★★★★ (1041)

48 in.16-Watt Cool White T8 or T12 Dimmable Linear LED Tube Light B...

\$19.94

[Product Overview](#)

[Specifications](#)

[Questions & Answers](#)

[Customer Reviews](#)

Specifications

Dimensions

Approximate Light Bulb Length	4 ft.	Product Height (in.)	1.5 in
Bulb Diameter (In.)	1.5	Product Length (in.)	48
		Product Width (in.)	1.5 in

Details

Actual Color Temperature (K)	4000	Light Bulb Base Code	T8/T12
Average Life (hours)	50000	Light Bulb Base Type	Bi-Pin
Bulb Construction	Plastic	Light Bulb Features	Ballast Bypass,Energy Saving,Lead Free,Low-Heat,Mercury Free,No Electromagnetic Interference,Non-Glare Optics,Shatter Proof
Bulb Shape	Linear	Light Bulb Shape Code	T8
Bulb Type	Tube	Lighting Technology	LED
Color Rendering Index (CRI)	83	Lumens (Brightness)	2000
Color Temperature	Cool White	Number of Bulbs Included	2
Dimmable/Non-Dimmable	Dimmable	Returnable	180-Day
Fixture Color/Finish	white	Wattage (Watts)	16
Indoor/Outdoor	Indoor	Wattage Equivalence	32

Warranty / Certifications

Manufacturer Warranty	lifetime residential warranty		
-----------------------	-------------------------------	--	--



Northern Lights Solutions

CECA/NECA University of Toronto Student Chapter



EcoSmart Model # 1003020502 ★★★★★ (370)

75-Watt Equivalent BR20 Dimmable Energy Star LED Light Bulb Soft W...

\$8.04

[Product Overview](#)

[Specifications](#)

[Questions & Answers](#)

[Customer Reviews](#)

Specifications

Dimensions

Bulb Diameter (in.)	2.52	Product Height (in.)	3.86
Product Depth (in.)	2.52	Product Width (in.)	2.52

Details

Actual Color Temperature (K)	2700	Light Bulb Base Type	Medium
Average Life (hours)	25000	Light Bulb Features	Dimmable,Energy Saving,Shatter Resistant
Bulb Construction	Plastic	Light Bulb Shape Code	BR20
Bulb Shape	Reflector	Lighting Technology	LED
Bulb Type	Flood and Spot	Lumens (Brightness)	940
Color Rendering Index (CRI)	80	Number of Bulbs Included	3
Color Temperature	Soft White	Returnable	180-Day
Fixture Color/Finish	Soft	Specialty Bulb Type	Flood & Spot
Indoor/Outdoor	Indoor	Wattage (Watts)	12
Light Bulb Base Code	E26	Wattage Equivalence	75

Warranty / Certifications

Manufacturer Warranty	5 Years		
-----------------------	---------	--	--



Lutron Model # CTCL-153PDH-WH ★★★★★ (1173)
Skylark Contour LED+ Dimmer Switch for Dimmable LED, Halogen and...

\$23⁹⁷



[Product Overview](#)

[Specifications](#)

[Questions & Answers](#)

[Customer Reviews](#)

Dimensions

Product Depth (in.)	1.75	Product Width (in.)	2
Product Height (in.)	4		

Details

Amperage (amps)	1.25	Indoor/Outdoor	Indoor
Color Family	White	Mounting Type	In-Wall
Color/Finish	White	Rating	General Purpose
Compatible Bulb Type	CFL, Halogen, Incandescent, LED	Returnable	180-Day
Control Type	Slide	Voltage	120 volt
Electrical Features	No Additional Features	Wattage (watts)	150
Electrical Product Type	Dimmer	Wired or Wireless	Wired

Warranty / Certifications

Certifications and Listings	UL Listed	Manufacturer Warranty	1 Year
-----------------------------	-----------	-----------------------	--------



Northern Lights Solutions

CECA/NECA University of Toronto Student Chapter

InLighten™ Light Shelf

Reducing Artificial
Lighting Needs



211 North Front Street Office Building, Harrisburg, PA
Architect: Murray Associates Architects, P.C., Harrisburg, PA
Glazing Contractor: Hershocks, Inc., Harrisburg, PA
Photo courtesy of Murray Associates Architects, P.C.

InLighten™ Light Shelf is a series of standard design elements that are assembled to passively channel natural daylighting into an occupied space. Kawneer's light shelf features an extruded aluminum chassis system and Aluminum Composite Material (ACM) panel surfaces. Assembled and erected, these components serve as an interior extension to a curtain wall horizontal, reflecting sunlight deeper into the interior of a building by "bouncing" natural light up

to the ceiling. Architectural light shelves have been proven to reduce requirements for perimeter artificial lighting, thereby conserving electrical energy costs. The InLighten™ Light Shelf represents another Kawneer solar control product solution, and is designed for integration with other Kawneer products.





Single Source Responsibility

InLighten™ can be attached directly to Kawneer's 2-1/2-inch profile curtain walls – 1600 Wall System®1 (outside glazed), System®2 (Structural Silicone Glazed), System®3 (inside/outside glazed) and System®5 (inside glazed).

Applications integrating InLighten™ with 1600 Wall System®1 and 1600 Wall System®5 can provide dual energy savings by incorporating 1600 SunShade®. On elevations with direct sunlight, the sunshade is designed to filter sunlight at the floor perimeter while the light shelf redirects sunlight deeper into the occupied space.

Aesthetics

Standard InLighten™ components incorporate considerable design flexibility:

- ACM panel surfaces are lightweight and available painted in a number of colors
- Extruded components can be painted or anodized
- Two options are available – the fascia cap and the continuous panel, which is also known as “Rout and Return”
- End caps have been designed to allow for punched window applications
- Custom fascia cap profiles can be developed

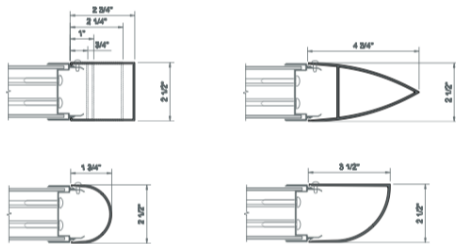

Fabrication

InLighten™ is field fabricated from stock length material. It is economical, lightweight and is easy to install and assemble. Screw-spline joinery is used for assembly of the shelf.

When InLighten™ is attached to 1600 Wall System®3 and System®5, outside glazed horizontal members are used for attachment strength.

For the Finishing Touch

Permadonic Anodized finishes are available in Class I and Class II in seven different colors.

Painted Finishes, including fluoropolymer that meet or exceed AAMA 2605, are offered in many standard choices and an unlimited number of specially-designed colors.

Solvent-free powder coatings add the “green” element with high performance, durability and scratch resistance that meet the standards of AAMA 2604.

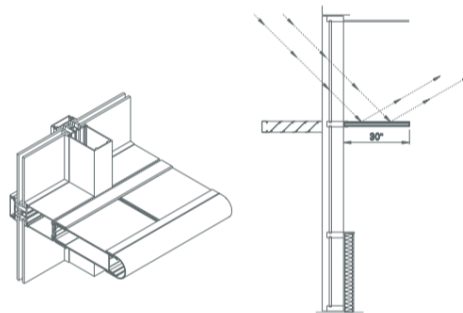



Room	Existing Lamp Type	Current Lamp unit price	Current wattage	Lux reading	Recommended LED Wattage	Lux or Luminance	LED Unit Price	Wattage Savings	Hours of Operation per week	Electricity cost (\$/kWh)	# of Bulbs	Savings per Year (\$)	Total Price of LED Units	Electricity Savings (kWh/yr)
1st floor - secondary hallway	T12	\$5.50	40	487	16	2000	\$10.00	24	70	\$0.13	24	\$204.42	\$240.00	1572480
1st floor - secondary hallway mezzanine	CFL	\$5.65	13		12	940	\$3.50	1	70		3	\$1.06	\$10.50	8190
1st floor - EXIT sign at Secondary hallway	CFL	\$5.65	13	179	12	940	\$3.50	1	70		1	\$0.35	\$3.50	2730
1st floor - Main hallway	CFL	\$5.65	13	97	12	940	\$3.50	1	70		12	\$1.42	\$42.00	10920
1st floor - VP office	T12	\$5.50	40		16	2000	\$10.00	24	52		8	\$50.62	\$80.00	389376
1st floor - Kindergarten room 1A	CFL	\$5.65	13	420	12	940	\$3.50	1	56		23	\$6.53	\$80.50	50232
1st floor - kindergarten room 1B	CFL	\$5.65	13	420	12	940	\$3.50	1	56		24	\$6.81	\$84.00	52416
1st floor CT	T12	\$5.50	40	82	16	2000	\$10.00	24	26		4	\$6.33	\$40.00	48672
3rd floor - room 20	T12	\$5.50	40	390	16	2000	\$10.00	24	52		24	\$151.86	\$240.00	1168128
3rd floor - room 24	T12	\$5.50	40	268	16	2000	\$10.00	24	52		10	\$63.27	\$100.00	486720
3rd floor - room 19	T12	\$5.50	40	990	16	2000	\$10.00	24	52		22	\$132.87	\$220.00	1022112
2nd floor - room 10	T12	\$5.50	40	606	16	2000	\$10.00	24	52		22	\$139.20	\$220.00	1070784
2nd floor - room 17	T12	\$5.50	40	97	16	2000	\$10.00	24	52		26	\$107.57	\$260.00	827424
2nd floor - secondary hallway	T12	\$5.50	40	245	16	2000	\$10.00	24	70		16	\$136.28	\$160.00	1048320
south stairwell - 1st floor	T12	\$5.50	40	128	16	2000	\$10.00	24	70		8	\$51.11	\$80.00	393120
South stairwell - 2nd floor	T12	\$5.50	40	354	16	2000	\$10.00	24	70		9	\$76.66	\$90.00	589680
South stairwell - 3rd floor	T12	\$5.50	40	2353	16	2000	\$10.00	24	70		6	\$51.11	\$60.00	393120
south stairwell - basement	T12	\$5.50	40	717	16	2000	\$10.00	24	70		4	\$34.07	\$40.00	262080
2nd floor - men's washroom	T12	\$5.50	40		16	2000	\$10.00	24	84		2	\$10.22	\$20.00	78624
2nd floor - women's washroom	T12	\$5.50	40		16	2000	\$10.00	24	84		2	\$20.44	\$20.00	157248
2nd floor - Nurse's office	T12	\$5.50	40	1056	16	2000	\$10.00	24	52		5	\$31.64	\$50.00	243360
3rd floor - room 23B	T12	\$5.50	40		16	2000	\$10.00	24	52		29	\$145.53	\$290.00	1119456
3rd floor - room 18	T8	\$5.50	32	990	16	2000	\$10.00	16	52		22	\$92.80	\$220.00	713856
1st floor - room 3 (child care)	T12	\$5.50	40	281	16	2000	\$10.00	24	56		46	\$279.38	\$460.00	2149056
1st floor - office annex/waiting area	T12	\$5.50	40	658	16	2000	\$10.00	24	52		22	\$139.20	\$220.00	1070784
3rd floor - hallway	T12	\$5.50	40	215	16	2000	\$10.00	24	70		8	\$68.14	\$80.00	524160
3rd floor - girls' washroom	T12	\$5.50	40		16	2000	\$10.00	24	84		6	\$61.33	\$60.00	471744
1st floor - room 5 (Kindergarten)	T12	\$5.50	40	573	16	2000	\$10.00	24	52		48	\$196.15	\$480.00	1508832
1st floor - room 2 (day care)	T12	\$5.50	40	1450	16	2000	\$10.00	24	56		50	\$306.63	\$500.00	2358720
1st floor - room 6 (kindergarten)	T12	\$5.50	40	823	16	2000	\$10.00	24	52		44	\$189.82	\$440.00	1460160



1st floor - room 7 (kindergarten)	T12	\$5.50	40	683	16	2000	\$10.00	24	52		44	\$240.44	\$440.00	1849536
1st floor - room 8 (kindergarten)	T12	\$5.50	40	323	16	2000	\$10.00	24	52		44	\$208.80	\$440.00	1606176
1st floor - room 8's washroom	CFL	\$5.65	13	1000	12	940	\$3.50	1	52		2	\$0.53	\$7.00	4056
1st floor - entrance 2 staircase	T12	\$5.50	40	354	16	2000	\$10.00	24	52		8	\$50.62	\$80.00	389376
1.5 floor - entrance 2 staircase	T12	\$5.50	40	107	16	2000	\$10.00	24	52		4	\$25.31	\$40.00	194688
2nd floor - entrance 2 staircase	T12	\$5.50	40	1153	16	2000	\$10.00	24	52		6	\$37.96	\$60.00	292032
2nd floor - room 15 (classroom)	T12	\$5.50	40	548	16	2000	\$10.00	24	52		44	\$246.77	\$440.00	1898208
2nd floor - room 12 (classroom)	T12	\$5.50	40	318	16	2000	\$10.00	24	52		44	\$278.40	\$440.00	2141568
2nd floor - library	T12	\$5.50	40	247	16	2000	\$10.00	24	84		120	\$899.46	\$1,200.00	6918912
2nd floor - hallway	T12	\$5.50	40	95	16	2000	\$10.00	24	70		16	-\$93.69	\$160.00	-720720
basement - entrance 2 staircase	T12	\$5.50	40	107	16	2000	\$10.00	24	10		4	\$4.87	\$40.00	37440
basement - room 28 (daycare)	T12	\$5.50	40	625	16	2000	\$10.00	24	56		24	\$149.91	\$240.00	1153152
basement - room 25 (child care)	T12	\$5.50	40	725	16	2000	\$10.00	24	56		28	\$129.47	\$280.00	995904
basement - room 26 (child care)	T12	\$5.50	40	744	16	2000	\$10.00	24	56		8	\$54.51	\$80.00	419328
basement - room 27 (child care)	T12	\$5.50	40	1056	16	2000	\$10.00	24	56		38	\$231.68	\$380.00	1782144
basement - room 28 (child care office)	T12	\$5.50	40	625	16	2000	\$10.00	24	56		24	\$149.91	\$240.00	1153152
basement - room 28 (kitchen)	T12	\$5.50	40	400	16	2000	\$10.00	24	26		8	\$25.31	\$80.00	194688
basement - room 28 (office)	T12	\$5.50	40	281	16	2000	\$10.00	24	56		32	\$190.79	\$320.00	1467648
basement - girls washroom	T12	\$5.50	40	838	16	2000	\$10.00	24	84		16	\$163.54	\$160.00	1257984
basement - boys washroom	T12	\$5.50	40	534	16	2000	\$10.00	24	84		14	\$143.10	\$140.00	1100736
basement - hallway (close to stairs 2)	T12	\$5.50	40	107	16	2000	\$10.00	24	70		8	\$68.14	\$80.00	524160
basement - hallway (close to dressing rooms)	T12	\$5.50	40	959	16	2000	\$10.00	24	70		6	\$51.11	\$60.00	393120
basement - hallway (close to stairs 1)	T12	\$5.50	40	717	16	2000	\$10.00	24	70		4	\$34.07	\$40.00	262080
basement - caretaker office	T12	\$5.50	40	570	16	2000	\$10.00	24	52		2	\$12.65	\$20.00	97344
basement - caretaker lunchroom	T12	\$5.50	40	1150	16	2000	\$10.00	24	26		8	\$25.31	\$80.00	194688
											TOTAL	\$6,091.79	\$10,437.50	46859.90
											Payback period (yrs):	1.71		



10 Appendix C – Product Data Sheets for Technical Analysis 3

PV Panels Comparison	Unit Cost (USD)	Power (W)	Type	Weight	Dimension	Efficiency (%)
Astronergy CHSM6612P/HV-345 Silver Poly Solar Panel	242	345	Poly	21.9 kg / 48.28 lbs.	77.17 × 39.06 × 1.57 in	18.00
Canadian Solar KuBlack CS3K-300MS 300W	202	300	Mono	18.5 kg (40.8 lbs.)	1675 X 992 X 35 mm (65.9 X 39.1 X 1.38 in)	18.05
Canadian Solar HiDM CS1H-330MS 330W	250	330	Mono	19.2 kg (42.3 lbs.)	1700 ×992 ×35 mm (66.9 ×39.1 ×1.38 in)	19.57
Canadian Solar HiDM CS1H-320MS 320W	214	320	Mono	19.2 kg (42.3 lbs.)	1700 ×992 ×35 mm (66.9 ×39.1 ×1.38 in)	18.98
SILFAB SIL-310W MONO SOLAR PANEL PALLET (QTY. 26)	4895 for 26	310	Mono	41.89 lbs.	66.93 x 39.37 x 1.50 inches	18.20

Inverter Comparison	Type	Unit Cost (USD)	Efficiency (%)	Output Power (W)	Output Voltage (AC)	Quantity
SMA Sunny TriPower 12000TL-US-10	String	2375	98.20	12000	120V	14
SMA Sunny TriPower 15000TL-US-10	String	N/A	98.20	15000	120V	12
SMA Sunny TriPower 20000TL-US-10	String	4377	98.50	20000	120V	9



HiDM
HIGH DENSITY MONO PERC MODULE
320 W ~ 345 W
CS1H-320 | 325 | 330 | 335 | 340 | 345MS

MORE POWER



Maximize the light absorption area, module efficiency up to 20.46 %



Low temperature coefficient (Pmax): -0.37 % / °C



Better shading tolerance

MORE RELIABLE



Lower internal current, lower hot spot temperature



Minimizes micro-crack impacts



Heavy snow load up to 5400 Pa, wind load up to 2400 Pa*



enhanced product warranty on materials and workmanship*



linear power output warranty*

*According to the applicable Canadian Solar Limited Warranty Statement.

MANAGEMENT SYSTEM CERTIFICATES*

ISO 9001:2015 / Quality management system
ISO 14001:2015 / Standards for environmental management system
OHSAS 18001:2007 / International standards for occupational health & safety

PRODUCT CERTIFICATES*

IEC 61215 / IEC 61730: VDE / CE / MCS / JET / INMETRO
UL 1703 / IEC 61215 performance: CEC listed (US) / PSEC (US Florida)
UL 1703: CSA / IEC 61701 ED2: VDE / IEC 62716: VDE
UNI 9177 Reaction to Fire: Class 1 / Take-e-way



As there are different certification requirements in different markets, please contact your local Canadian Solar sales representative for the specific certificates applicable to the products in the region in which the products are to be used.

CANADIAN SOLAR INC. is committed to providing high quality solar products, solar system solutions and services to customers around the world. No. 1 module supplier for quality and performance/price ratio in IHS Module Customer Insight Survey. As a leading PV project developer and manufacturer of solar modules with over 38 GW deployed around the world since 2001.

* For detail information, please refer to Installation Manual.

CANADIAN SOLAR INC.

545 Speedvale Avenue West, Guelph, Ontario N1K 1E6, Canada, www.canadiansolar.com, support@canadiansolar.com



ENGINEERING DRAWING (mm)

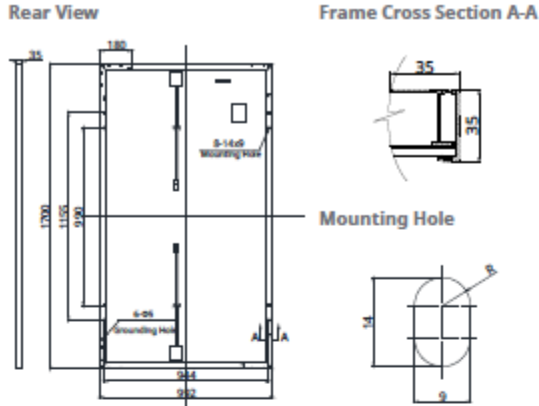

CS1H-330MS / I-V CURVES

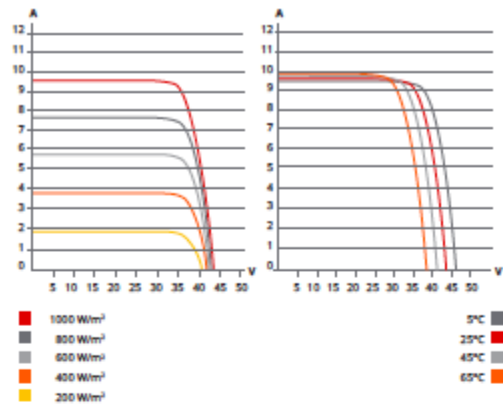

ELECTRICAL DATA | STC*

CS1H	320MS	325MS	330MS	335MS	340MS	345MS
Nominal Max. Power (Pmax)	320 W	325 W	330 W	335 W	340 W	345 W
Opt. Operating Voltage (Vmp)	36.2 V	36.6 V	37.0 V	37.4 V	37.8 V	38.2 V
Opt. Operating Current (Imp)	8.85 A	8.88 A	8.92 A	8.96 A	9.00 A	9.04 A
Open Circuit Voltage (Voc)	44.0 V	44.1 V	44.2 V	44.3 V	44.5 V	44.6 V
Short Circuit Current (Isc)	9.60 A	9.64 A	9.68 A	9.72 A	9.76 A	9.80 A
Module Efficiency	18.98%	19.27%	19.57%	19.86%	20.16%	20.46%
Operating Temperature	-40°C ~ +85°C					
Max. System Voltage	1500V (IEC) or 1000V (IEC/UL)					
Module Fire Performance	TYPE 1 (UL 1703) or CLASS C (IEC 61730)					
Max. Series Fuse Rating	16 A					
Application Classification	Class A					
Power Tolerance	0 ~ +5 W					

* Under Standard Test Conditions (STC) of irradiance of 1000 W/m², spectrum AM 1.5 and cell temperature of 25°C.

MECHANICAL DATA

Specification	Data
Cell Type	Mono-crystalline
Dimensions	1700 x 992 x 35 mm (66.9 x 39.1 x 1.38 in)
Weight	19.2 kg (42.3 lbs)
Front Cover	3.2 mm tempered glass
Frame	Anodized aluminium alloy
J-Box	IP68, 3 bypass diodes
Cable	4.0 mm ² (IEC), 12 AWG (UL)
Cable Length (Including Connector)	1350 mm (53.1 in)
Connector	T4 series or H4 UTX or MC4-EVO2
Per Pallet	30 pieces
Per Container (40' HQ)	780 pieces

ELECTRICAL DATA | NMOT*

CS1H	320MS	325MS	330MS	335MS	340MS	345MS
Nominal Max. Power (Pmax)	237 W	241 W	244 W	248 W	252 W	255 W
Opt. Operating Voltage (Vmp)	33.5 V	33.9 V	34.2 V	34.6 V	35.0 V	35.3 V
Opt. Operating Current (Imp)	7.07 A	7.11 A	7.14 A	7.17 A	7.20 A	7.23 A
Open Circuit Voltage (Voc)	41.1 V	41.2 V	41.3 V	41.4 V	41.6 V	41.7 V
Short Circuit Current (Isc)	7.75 A	7.78 A	7.81 A	7.85 A	7.88 A	7.91 A

* Under Nominal Module Operating Temperature (NMOT), irradiance of 800 W/m²-spectrum AM 1.5, ambient temperature 20°C, wind speed 1 m/s.

TEMPERATURE CHARACTERISTICS

Specification	Data
Temperature Coefficient (Pmax)	-0.37 % / °C
Temperature Coefficient (Voc)	-0.29 % / °C
Temperature Coefficient (Isc)	0.05 % / °C
Nominal Module Operating Temperature	43±3 °C

PARTNER SECTION



The specifications and key features contained in this datasheet may deviate slightly from our actual products due to the on-going innovation and product enhancement. Canadian Solar Inc. reserves the right to make necessary adjustment to the information described herein at any time without further notice. Please be kindly advised that PV modules should be handled and installed by qualified people who have professional skills and please carefully read the safety and installation instructions before using our PV modules.

CANADIAN SOLAR INC.

545 Speedvale Avenue West, Guelph, Ontario N1K 1E6, Canada, www.canadiansolar.com, support@canadiansolar.com



PR2

BALLASTED FLAT ROOF SYSTEM

The PR2 Ballasted Flat Roof System is the ideal solution for roofs with low reserve loads or geographic areas with high snow and/or wind loads. Its superior grid architecture makes it the lightest ballasted solution in the industry.

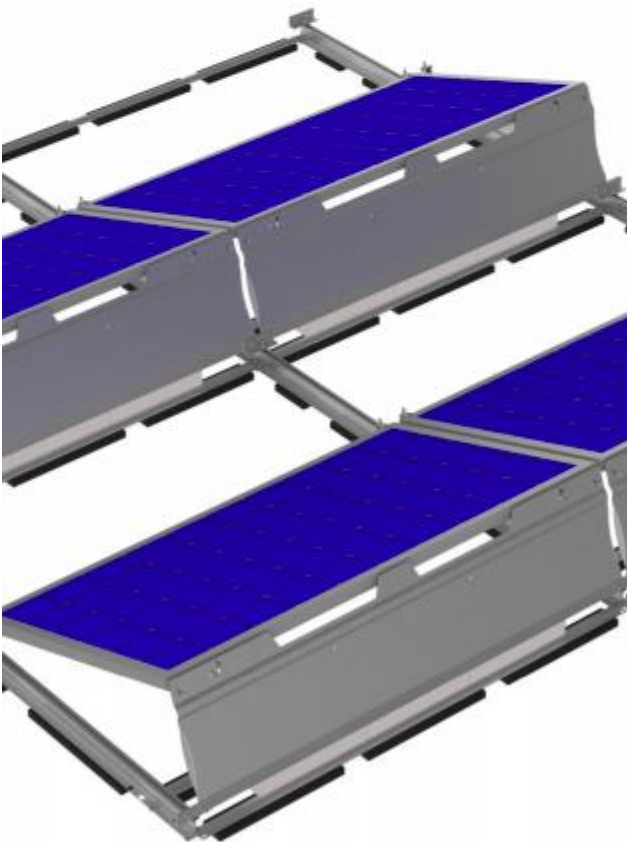

KEY PRODUCT BENEFITS

- Average load <3psf on roof
- 30% faster install time (1 fastener – 1 tool)
- Only 3 components & 1 fasteners
- Adjust to varying roof slopes
- FastCAD system for improved revision management
- Full visual access to module from all sides
- Easy access to roof anytime
- 10 year warranty

KEY TECHNICAL FEATURES

- 100% aluminum with stainless steel fasteners
- Extreme weight distribution minimizes point loading
- Integrated combiners reduces footprint
- Ballast under the module for safety
- Low torque frequency (3 years)
- Single panel modular design allows for flexibility around roof obstructions maximizing available space
- Integrated bonding
- Optional Anchor/Hybrid solution available

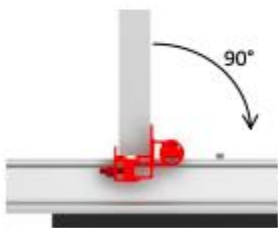
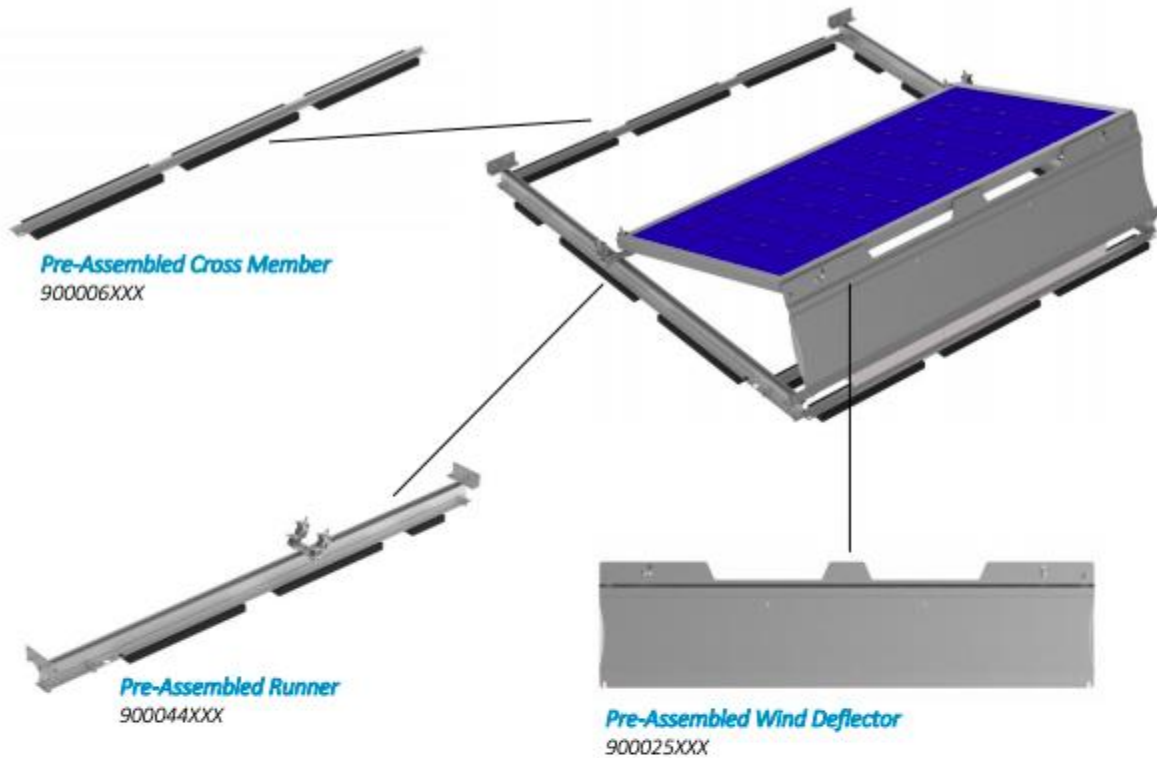

*Standard Rotating Front
Clamp for all Tilts*



*Snap-in Cross Member
Connection*



Bay to Bay Bonding



*Module Bonding
through J-Clamp*



This document does not create any express warranty by Polar Racking, about its products or services. Polar Racking's sole warranty is contained in the written product manual for each product. The end-user documentation shipped with Polar Racking's products constitutes the sole specification referred to the product warranty. The customer is solely responsible for verifying the suitability of Polar Racking's product for each use. Subject to change without notice. Last update, September 2015.

1.416.860.6722 www.polarracking.com



Specification	
Model	ECO-PV6
Input Circuits/Circuit Breakers	6
Circuit Breaker Rating	10A
Max Total DC Output Current	60A
Max Input Voltage Rating	250V
Max Output Voltage Rating	250V
Protection Grade	IP65
Operational Environment Temperature	-30~+70°C
Relative Humidity	0-95%
Cooling Method	Natural Cooling
Surge Lightning Protection	Yes
Dimension	260*320*115mm(10.3"x12.6"x4.5")
Weight	5.1kg (11.22lbs)

Package Included

- 1 pc 6 String PV Combiner Box
- 1 pc User Manual

Features

- 6 string configuration, 10A circuit breakers.
- Each string continuous duty rated at 250 Vdc.
- Photovoltaic high-voltage protection.
- Each string with high-voltage fuses, over-voltage & over-current protection.
- Lightning arrester for both poles.
- Anti-backflow diodes, anti-backflow & anti-reverse protection.
- Circuit breaker output control, short-circuit fault protection, safe and reliable.
- Protection class IP65 for outdoor installation requirements.
- Touch-safe circuit breakers & non-conductive box.
- All UL compliant components used.
- Includes output cable glands & safety labels.
- Includes lightning/surge protection module (1000V).



SUNNY TRIPOWER 12000TL-US / 15000TL-US / 20000TL-US / 24000TL-US



<p>Design flexibility</p> <ul style="list-style-type: none"> • 1000 V DC or 600 V DC • Two independent DC inputs • 15° to 90° mounting angle range • Detachable DC Connection Unit 	<p>System efficiency</p> <ul style="list-style-type: none"> • 98% CEC, 98.5% Peak • 1000 V DC increases system efficiency • OptiTrac advanced MPPT • OptiTrac Global Peak MPPT 	<p>Enhanced safety</p> <ul style="list-style-type: none"> • Integrated DC AFCI • Floating system with all-pole sensitive ground fault protection • Reverse polarity indicator 	<p>Future-proof</p> <ul style="list-style-type: none"> • Cluster Controller, WebConnect/Speedwire • Bi-directional Ethernet communications • Complete grid management feature set • Ability to satisfy future utility requirements
---	---	---	---

SUNNY TRIPOWER 12000TL-US / 15000TL-US / 20000TL-US / 24000TL-US

The ultimate solution for decentralized PV plants

SMA's new Sunny Tripower TL-US is raising the level of performance for decentralized commercial PV plants. This three-phase transformerless inverter is UL listed for up to 1000 V DC maximum system voltage and has peak efficiency above 98 percent, while OptiTrac Global Peak minimizes the effects of shade for maximum energy production. The Sunny Tripower delivers a future-proof solution with full grid management, and communications and monitoring features. The Sunny Tripower is also equipped with all-pole ground fault protection and integrated AFCI for a safe, reliable solution. It offers unmatched flexibility with a wide input voltage range and two independent MPP trackers. Suitable for both 600 V DC and 1,000 V DC applications, the Sunny Tripower allows for flexible design and a lower levelized cost of energy.



Technical data	Sunny Tripower 12000TL-US	Sunny Tripower 15000TL-US	Sunny Tripower 20000TL-US	Sunny Tripower 24000TL-US
Input (DC)				
Max. recommended PV power (@ module STC)	15000 W	18750 W	25000 W	30000 W
Max. DC voltage*	1000 V	1000 V	1000 V	1000 V
Rated MPPT voltage range	300 V...800 V	300 V...800 V	380 V...800 V	450 V...800 V
MPPT operating voltage range	150 V...1000 V	150 V...1000 V	150 V...1000 V	150 V...1000 V
Min. DC voltage / start voltage	150 V / 188 V	150 V / 188 V	150 V / 188 V	150 V / 188 V
Number of MPP tracker inputs	2	2	2	2
Max. input current / per MPP tracker input	66 A / 33 A	66 A / 33 A	66 A / 33 A	66 A / 33 A
Output (AC)				
AC nominal power	12000 W	15000 W	20000 W	24000 W
Max. AC apparent power	12000 VA	15000 VA	20000 VA	24000 VA
Output phases / line connections	3 / 3-N-PE			
Nominal AC voltage	480 / 277 V WYE			
AC voltage range	244 V...305 V			
Rated AC grid frequency	60 Hz			
AC grid frequency / range	50 Hz, 60 Hz / 44 Hz...65 Hz			
Max. output current	14.4 A	18 A	24 A	29 A
Power factor at rated power / adjustable displacement	1 / 0.8 leading...0.8 lagging			
Harmonics	< 3 %			
Efficiency				
Max. efficiency	98.2 %	98.2 %	98.5 %	98.5 %
CEC efficiency	97.5%	97.5%	97.5%	98.0%
Protection devices				
DC reverse polarity protection	●	●	●	●
Ground fault monitoring / Grid monitoring	●	●	●	●
All-pole sensitive residual current monitoring unit	●	●	●	●
DC AFCI compliant to UL 1699B	●	●	●	●
AC short circuit protection	●	●	●	●
Protection class / overvoltage category	I / IV	I / IV	I / IV	I / IV
General data				
Dimensions (W / H / D) in mm (in)	665 / 690 / 265 (26.1 / 27.1 / 10.4)			
Packing dimensions (W / H / D) in mm (in)	780 / 790 / 380 (30.7 / 31.1 / 15.0)			
Weight	55 kg (121 lbs)			
Packing weight	61 kg (134.5 lbs)			
Operating temperature range	-25°C...+60°C			
Noise emission (typical)	51 dB(A)			
Internal consumption at night	1 W			
Topology	Transformerless			
Cooling concept	OptiCool			
Electronics protection rating	NEMA 3R			
Features				
Display / LED indicators (Status / Fault / Communication)	- / ●	- / ●	- / ●	- / ●
Interfaces: Speedwire / RS485	● / ○	● / ○	● / ○	● / ○
Mounting Angle Range	15°...90°	15°...90°	15°...90°	15°...90°
Warranty: 10 / 15 / 20 years	● / ○ / ○	● / ○ / ○	● / ○ / ○	● / ○ / ○
Certifications and approvals (pending)	UL 1741, UL 1998, UL 1699B, IEEE 1547, FCC Part 15 (Class A & B), CAN/CSA C22.2 107.1-1			
NOTE: US inverters ship with gray lids				
* Suitable for 600 V DC max. systems				
Type designation	STP 12000TL-US-10	STP 15000TL-US-10	STP 20000TL-US-10	STP 24000TL-US-10

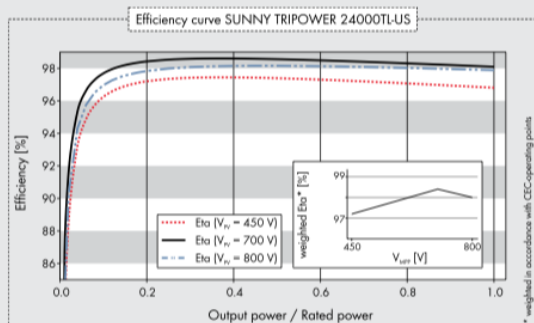

Accessories



RS485 interface
DM-485CB-US-10



SMA Cluster Controller
CLCON-10

● Standard features ○ Optional features – Not available
Data at nominal conditions



11 Appendix D – Volunteering Log

Content	Release Date	Type of Activity	Hours Spent	Volunteers
Energy Lesson	April 22, 2020	- Preparing lesson: meeting, brainstorming activities/resources/video content, blog post - Preparing video: recording, editing	Elementary: 4	Niloufar, Rose, Pavani
			Intermediate: 4.5	Noah, Nicole, Alexa
Building Materials Lesson	May 6, 2020	- Preparing lesson: meeting, brainstorming activities/resources/video content, blog post - Preparing video: recording, editing	Elementary: 4	Niloufar, Rose, Pavani
			Intermediate: 4	Noah, Nicole, Alexa
Wellbeing Lesson	May 20, 2020	- Preparing lesson: meeting, brainstorming activities/resources/video content, blog post - Preparing video: recording, editing	Elementary: 4	Niloufar, Rose, Pavani
			Intermediate: 4	Noah, Nicole, Alexa
Power Dilemma Web Game	June 1, 2020	- Meeting, brainstorming - Creating game: graphics design, coding	40	Noah, Niloufar
Total number of hours volunteered = 64.5 hours Number of different volunteers = 6 Cumulative "average volunteer hours per team team member" = $64.5/6 = 10.75$ hours				